

**TECHNICAL
INFORMATION**

In the interest of continuing product improvement,
we reserve the right to change models,
specifications, and/or features without prejudice.

PROJECT: _____
 LOCATION: _____
 ARCHITECT: _____
 ENGINEER: _____
 CONTRACTOR: _____
 DATE: _____ SALES ENGINEER: _____

EXPLODED VIEW OF SERIES 15000 ARM FOR WALL/COLUMN MOUNT

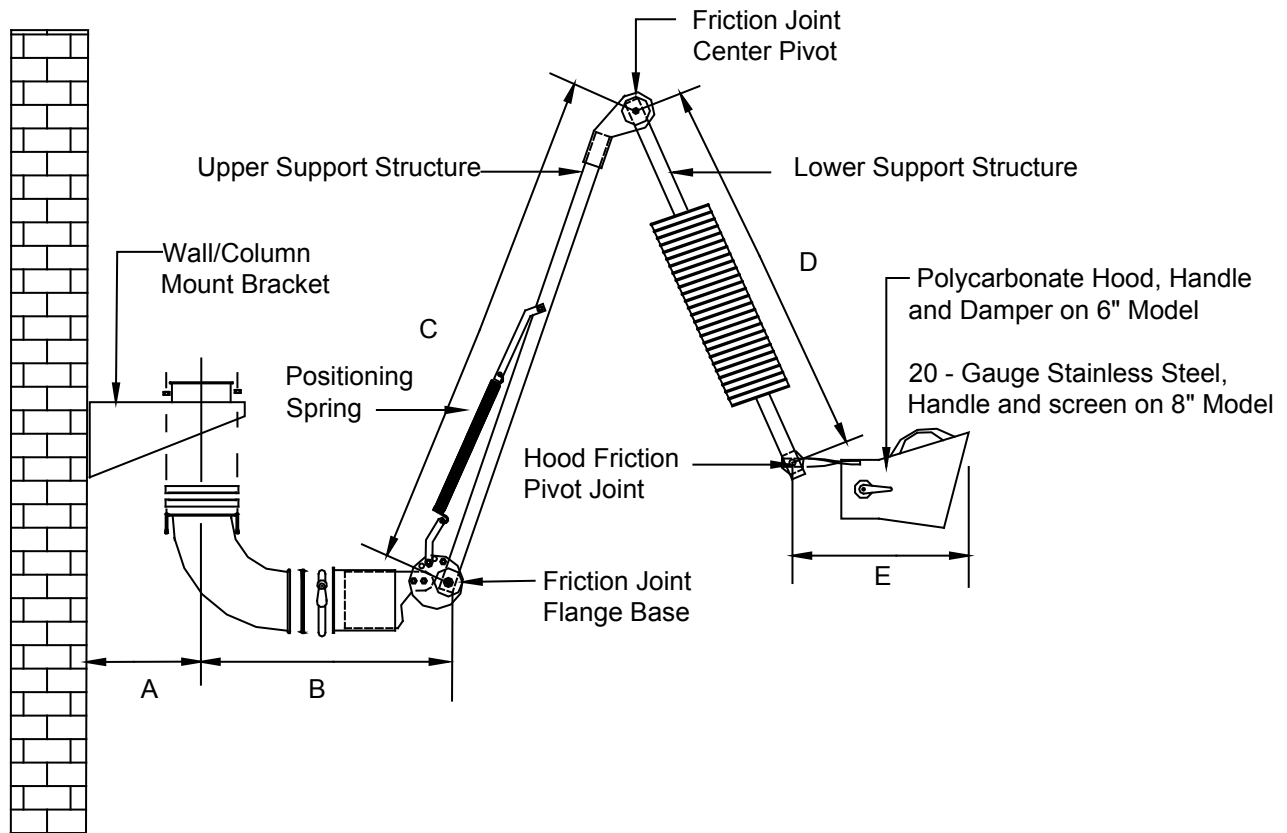

6" Model	Dimensions, Inches, 15000 Arms					Weights (lbs.)
	A	B	C	D	E	
15076	12"	19"	34"	22"	17"	48
15106	12"	19"	54"	42"	17"	54
15146	12"	19"	73"	61"	17"	64
8" Model	Dimensions, Inches, 15000 Arms					Weights (lbs.)
	A	B	C	D	E	
15078	12"	25"	34"	22"	17"	54
15108	12"	25"	54"	42"	17"	60
15148	12"	25"	73"	61"	17"	72

Note: See other WSC pages for detail information for wall/column bracket, swivel collar, flanged swivel elbow, gasket and joint clamp