

TECHNICAL INFORMATION

In the interest of continuing product improvement,
we reserve the right to change models,
specifications, and/or features without prejudice.

PROJECT: _____
 LOCATION: _____
 ARCHITECT: _____
 ENGINEER: _____
 CONTRACTOR: _____
 DATE: _____ SALES ENGINEER: _____

www.monoxivent.com

info@monoxivent.com

309-794-1000

Page: EF-15

Wheel Diameter - 10"
 Wheel Type - Flatblade
 Tip Speed (FPM) = 2.62 x RPM
 Max. BHP = .027 x (RPM/1000)³
 Inlet Area - .61 Sq. Ft.
 Outlet Area - .57 Sq. Ft.
 Outlet Velocity (FPM) = CFM/.57
 Max. Mtr. Frame Size - 145T, Arr. 10
 Approx. Shipping Weight
 BI-100 - 173 lbs.

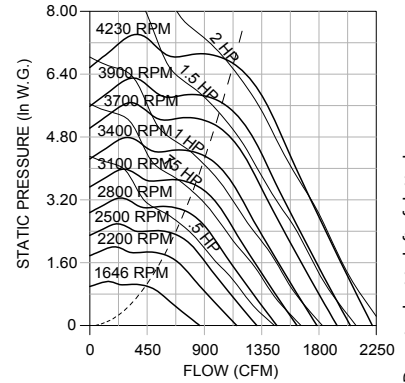
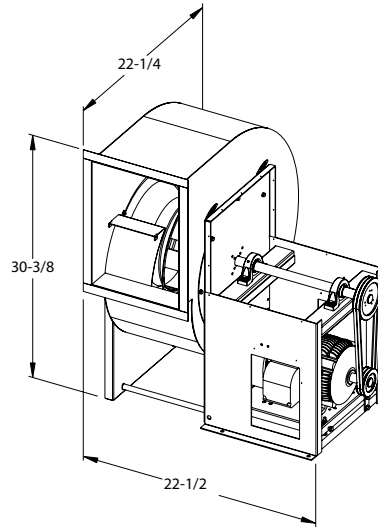

CFM	OV	1.000 SP		1.250 SP		1.500 SP		1.750 SP		2.000 SP		2.500 SP		3.000 SP		3.500 SP		4.000 SP		4.500 SP		5.000 SP	
		RPM	BHP	RPM	BHP	RPM	BHP	RPM	BHP	RPM	BHP	RPM	BHP	RPM	BHP	RPM	BHP	RPM	BHP	RPM	BHP	RPM	BHP
450	783	1646	.12																				
550	957	1739	.15	1877	.18	2015	.22																
650	1131	1872	.18	1987	.22	2103	.26	2220	.30	2338	.35												
750	1305	2023	.23	2128	.27	2227	.31	2327	.35	2428	.40	2631	.50										
850	1479	2177	.28	2280	.33	2373	.37	2462	.42	2550	.47	2726	.57	2906	.68	3085	.80						
950	1653	2333	.34	2434	.39	2526	.44	2612	.50	2693	.55	2851	.65	3008	.77	3168	.89	3329	1.02				
1050	1827	2492	.40	2589	.46	2680	.52	2766	.58	2845	.64	2993	.75	3135	.87	3277	.99	3422	1.12	3567	1.26	3712	1.41
1150	2002	2654	.49	2748	.54	2836	.60	2920	.67	2999	.73	3144	.86	3278	.99	3408	1.11	3538	1.25	3668	1.39	3801	1.54
1250	2176	2820	.58	2909	.64	2995	.70	3075	.77	3153	.84	3298	.98	3429	1.12	3553	1.26	3673	1.39	3791	1.53	3911	1.68
1350	2350	2987	.70	3073	.76	3156	.82	3234	.89	3310	.96	3452	1.11	3583	1.26	3704	1.41	3819	1.56	3930	1.71	4040	1.86
1450	2524	3157	.82	3239	.89	3319	.95	3395	1.02	3469	1.09	3608	1.25	3737	1.41	3857	1.58	3970	1.74	4078	1.90	4182	2.05
1550	2698	3328	.96	3408	1.03	3485	1.10	3559	1.17	3630	1.25	3765	1.40	3891	1.57	4011	1.75	4123	1.93	4229	2.10		
1650	2872	3501	1.12	3579	1.20	3653	1.27	3724	1.35	3793	1.42	3924	1.58	4048	1.75	4166	1.94						
1750	3046	3677	1.29	3751	1.38	3822	1.46	3891	1.54	3958	1.62	4085	1.78	4206	1.95								
1850	3220	3851	1.48	3924	1.58	3993	1.66	4059	1.75	4124	1.83												
1950	3394	4030	1.69	4099	1.79	4166	1.89	4231	1.98														

Performance certified is for installation type B: Free inlet, Ducted outlet. Power rating (BHP) does not include transmission losses. Performance ratings do not include the effects of appurtenances (accessories).