

TECHNICAL INFORMATION

In the interest of continuing product improvement,
we reserve the right to change models,
specifications, and/or features without prejudice.

PROJECT: _____
LOCATION: _____
ARCHITECT: _____
ENGINEER: _____
CONTRACTOR: _____
DATE: _____ SALES ENGINEER: _____

Wall/column mount arm
Series 15000 - Hose
diameters - 6" & 8"

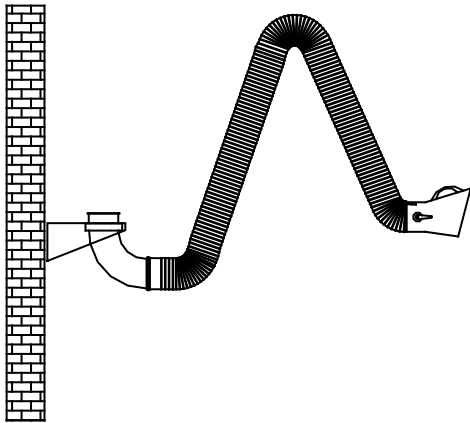

Duct mount arm

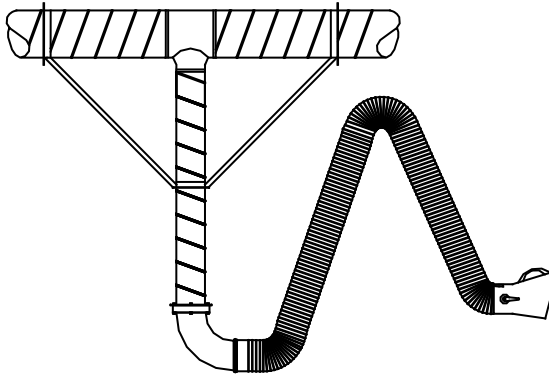

Telescopic arm - available
for wall/column and duct
mounting

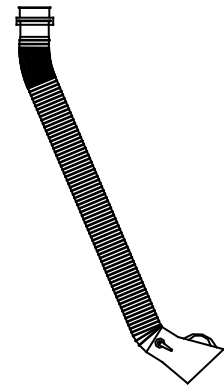

Portable mount arm

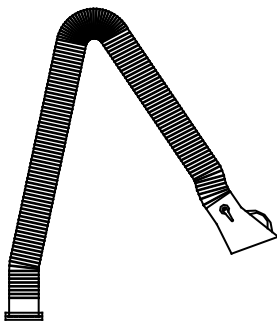

Boom mounted arm - Series 15000-BA, hose diameter 6" or 8"

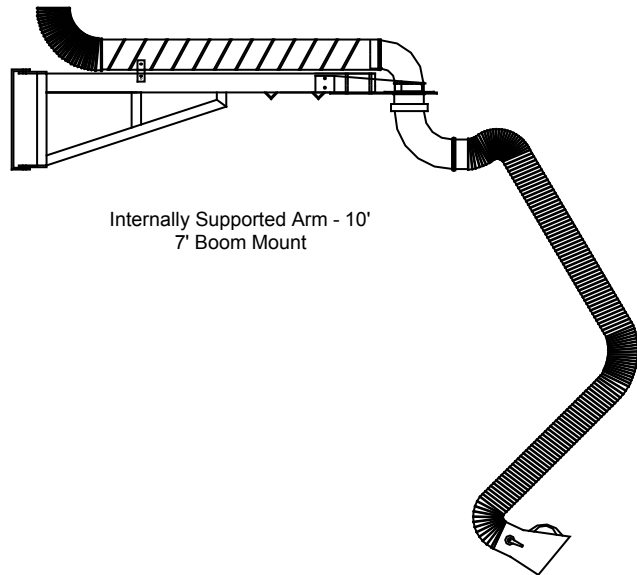

Internally Supported Arm - 10'
7' Boom Mount