

TECHNICAL INFORMATION

In the interest of continuing product improvement,
we reserve the right to change models,
specifications, and/or features without prejudice.

PROJECT: _____
LOCATION: _____
ARCHITECT: _____
ENGINEER: _____
CONTRACTOR: _____
DATE: _____ SALES ENGINEER: _____

SWIVEL BOOM - INTERNAL FLEXIBLE ARM

The 15000-BA is a package consisting of the Swivel Boom and self supporting Flex Arm that mounts on the end.

Swivel Boom is available in 7', 10' and 13' lengths.
Flex Arm is available in 7', 10' and 14' lengths

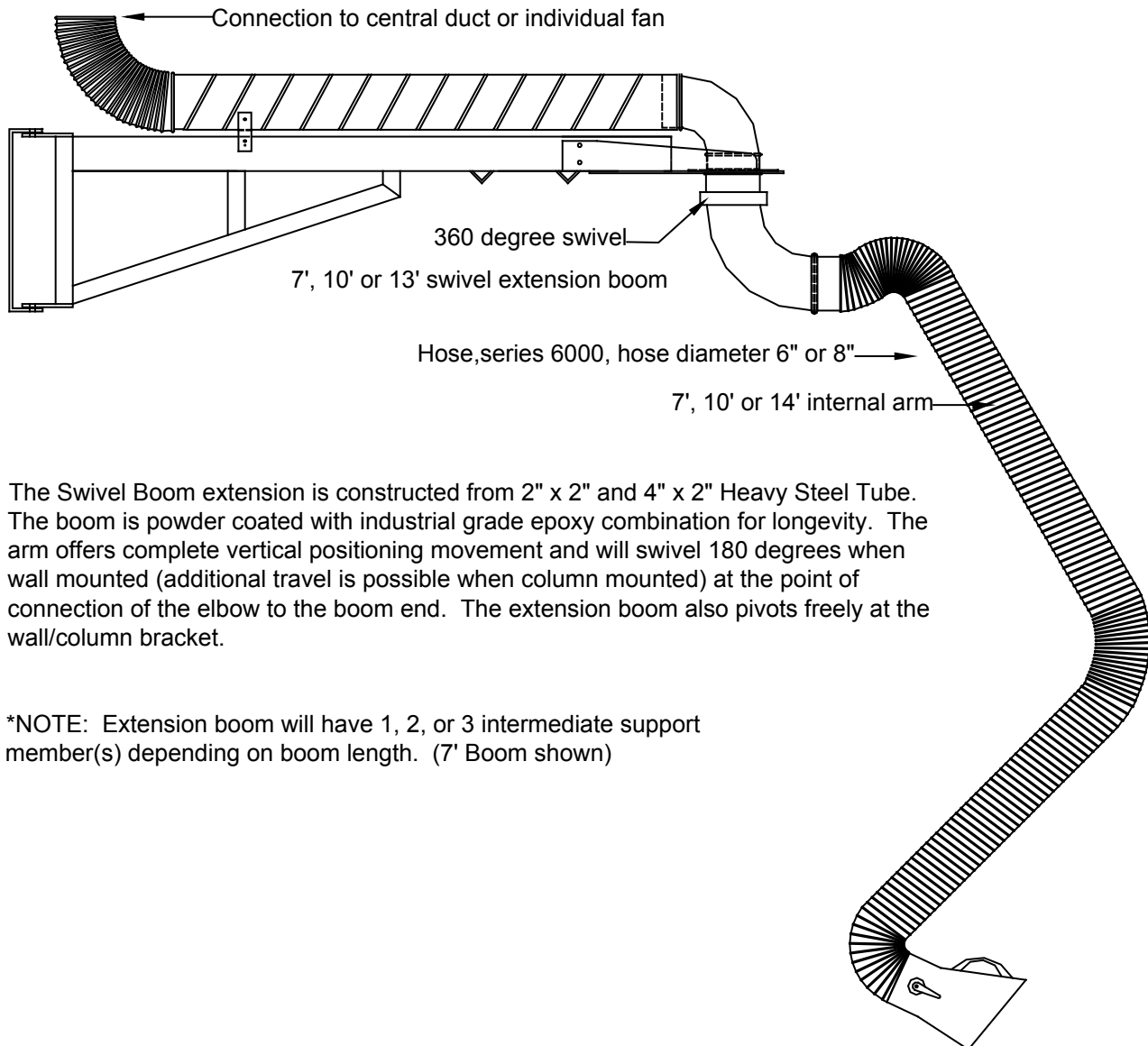

The Swivel Boom extension is constructed from 2" x 2" and 4" x 2" Heavy Steel Tube. The boom is powder coated with industrial grade epoxy combination for longevity. The arm offers complete vertical positioning movement and will swivel 180 degrees when wall mounted (additional travel is possible when column mounted) at the point of connection of the elbow to the boom end. The extension boom also pivots freely at the wall/column bracket.

*NOTE: Extension boom will have 1, 2, or 3 intermediate support member(s) depending on boom length. (7' Boom shown)