

**TECHNICAL
INFORMATION**

Pivoting Articulated
Crane, Using Self
Supported Arm Options

In the interest of continuing product improvement,
we reserve the right to change models,
specifications, and/or features without prejudice.

PROJECT: _____
 LOCATION: _____
 ARCHITECT: _____
 ENGINEER: _____
 CONTRACTOR: _____
 DATE: _____ SALES ENGINEER: _____

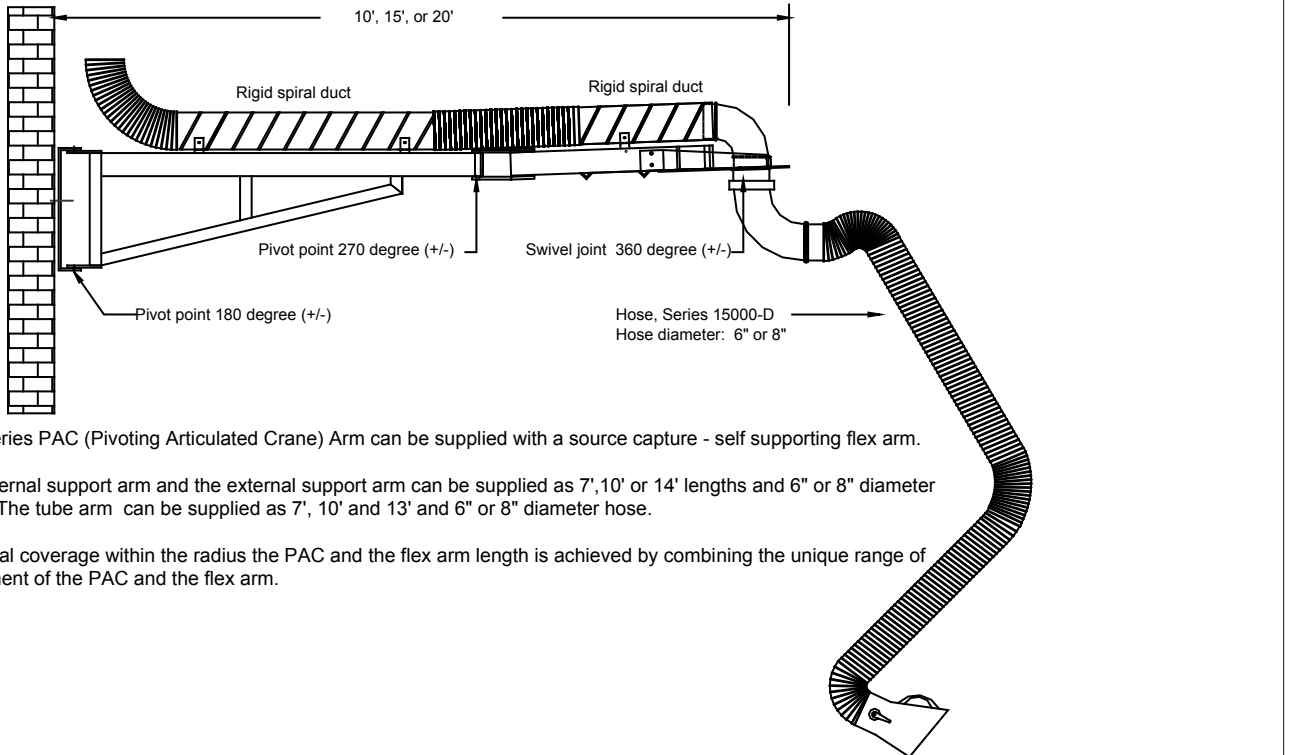

The Series PAC (Pivoting Articulated Crane) Arm can be supplied with a source capture - self supporting flex arm.

The internal support arm and the external support arm can be supplied as 7', 10' or 14' lengths and 6" or 8" diameter hose. The tube arm can be supplied as 7', 10' and 13' and 6" or 8" diameter hose.

The total coverage within the radius the PAC and the flex arm length is achieved by combining the unique range of movement of the PAC and the flex arm.

