

**TECHNICAL
INFORMATION**

In the interest of continuing product improvement,
we reserve the right to change models,
specifications, and/or features without prejudice.

PROJECT: _____
 LOCATION: _____
 ARCHITECT: _____
 ENGINEER: _____
 CONTRACTOR: _____
 DATE: _____ SALES ENGINEER: _____

www.monoxivent.com

info@monoxivent.com

309-794-1000

Page: EF-22

Wheel Diameter - 21"
 Wheel Type - Flatblade
 Tip Speed (FPM) = 5.50 x RPM
 Max. BHP = 1.11 x (RPM/1000)³
 Inlet Area - 2.69 Sq. Ft.
 Outlet Area - 2.57 Sq. Ft.
 Outlet Velocity (FPM) = CFM/2.57
 Max. Mtr. Frame Size - 215T, Arr. 10
 Approx. Ship Wt.
 BI-210 - 490 lbs.

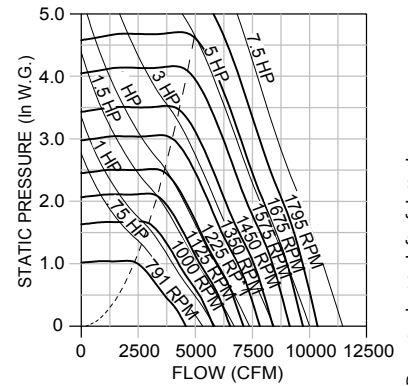
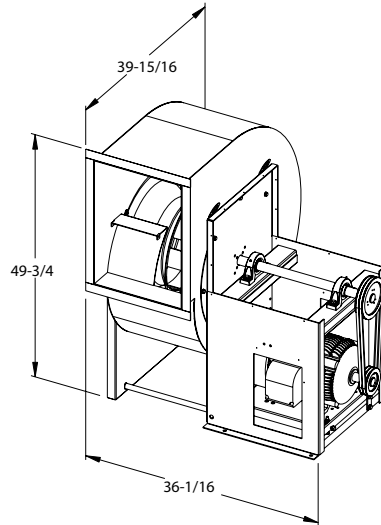

CFM	OV	1.000 SP		1.250 SP		1.500 SP		1.750 SP		2.000 SP		2.500 SP		3.000 SP		3.500 SP		4.000 SP		4.500 SP		5.000 SP	
		RPM	BHP	RPM	BHP	RPM	BHP	RPM	BHP	RPM	BHP	RPM	BHP	RPM	BHP	RPM	BHP	RPM	BHP	RPM	BHP	RPM	BHP
2500	974	791	0.53																				
2950	1149	834	0.64	897	0.79	961	0.95																
3400	1325	886	0.78	943	0.93	999	1.10	1054	1.27	1109	1.46												
3850	1500	943	0.94	996	1.10	1047	1.28	1097	1.46	1146	1.65	1243	2.06										
4300	1676	1003	1.12	1054	1.31	1101	1.49	1148	1.69	1193	1.89	1281	2.31	1368	2.76								
4750	1851	1064	1.34	1113	1.53	1159	1.74	1203	1.94	1245	2.15	1327	2.59	1407	3.06	1486	3.56	1565	4.08				
5200	2026	1125	1.58	1175	1.80	1219	2.02	1261	2.24	1301	2.46	1379	2.92	1454	3.41	1526	3.91	1599	4.46	1671	5.02		
5650	2202	1185	1.84	1236	2.09	1280	2.33	1321	2.57	1361	2.81	1435	3.30	1505	3.80	1574	4.33	1641	4.88	1707	5.45	1774	6.05
6100	2377	1244	2.13	1296	2.41	1341	2.67	1383	2.94	1421	3.19	1492	3.71	1560	4.24	1626	4.79	1689	5.35	1752	5.95		
6550	2553	1305	2.46	1355	2.76	1402	3.05	1444	3.34	1482	3.61	1552	4.16	1618	4.73	1680	5.29	1741	5.88				
7000	2728	1369	2.82	1415	3.14	1461	3.45	1504	3.77	1543	4.07	1613	4.67	1677	5.26	1738	5.86						
7450	2903	1435	3.23	1476	3.55	1521	3.90	1564	4.24	1603	4.56	1674	5.21	1737	5.83								
7900	3079	1502	3.68	1541	4.02	1582	4.38	1623	4.74	1663	5.09	1735	5.79										
8350	3254	1571	4.18	1607	4.54	1645	4.91	1683	5.27	1722	5.66												
8800	3430	1642	4.74	1674	5.10	1708	5.47	1745	5.87	1783	6.27												
9250	3605	1713	5.35	1744	5.73	1776	6.12																