

MONOXIVENT®

Source Capture Systems

Operation, Maintenance and Installation Manual

XL Hose Reel



MONOXIVENT - SOURCE CAPTURE SYSTEMS

1306 Mill St., Rock Island, IL 61201
877-608-4383 - info@monoxivent.com
monoxivent.com

Mar. - 2017

Oversize Motor Operated Hose Reel Installation and Maintenance Instructions

- 1.** Read and understand all instructions prior to starting installation.
- 2.** Inspect all equipment when delivered. Report and indicate any damage on freight bill.
- 3.** Remove packing material from the hose reel and inspect for hidden damages. If any hidden damage is found, notify the freight carrier immediately and arrange for the carrier to make an inspection.
- 4.** Install the hose reel in a location as directed by the owner. The reel must be mounted to rigid building structural support members. Mounting hardware to be a minimum Grade 8 to include bolts, lock nuts, washers and lock washers. Hanging the reel from threaded rod is not acceptable. The reel must be installed level and plumb using all end and mid point bolt holes. Once installed, as the complete assembly must be re-checked for level and plumb. Adjust as required.
- 5.** Install the motorized hose reel up/down switch in a location as directed by the owner. Securely attach the up/down switch to a wall or column. The up/down switch should be mounted in the work bay that serves its' respective hose reel.
- 6.** Determine the wire routing from the primary power source to the motorized hose reel. Wire from the primary power source to the motorized hose reel. Follow all NEC and local codes as applicable.
- 8.** Confirm that all wiring is correct before turning on main power source.
- 9.** Turn on main power source. Test up/down operation of hose reel. Run hose reel through several complete up/down cycles to confirm proper operation.
- 10.** Adjust up/down limit switches if necessary. The motorized hose reel should not over rotate in either direction, up or down. If the reel over rotates going up you risk potential damage to the reel, nozzle, and flex hose. If the reel over rotates going down you risk potential damage to the reel and flex hose.

Operation

1. With the hose in the fully stored position, depressing the down button on the wall mounted up/down switch will lower the flex hose. Lower the hose only the required amount to reach the vehicles tailpipe. Do not unwind the hose completely from the hose reel.
2. Attach the tailpipe adapter over the vehicles tailpipe.
3. When the vehicles service is complete, and before driving the vehicle from the bay, remove the tailpipe adapter from the vehicles tailpipe. Depress the up button on the well mounted up/down switch and completely wind hose back on to storage reel.
4. Moving vehicle with hose reel attached could result in sever damage to the hose reel assembly, the building structure and the vehicle itself.

Maintenance

1. Thoroughly clean the hose reel inner tube and hose drum surfaces as required.
2. The bearing at the discharge end of hose storage reel is a high temperature permanently lubricated bearing. Inspect this bearing for wear by removing the discharge duct. Upon inspection reattach discharge duct.
3. Remove the motor cover to grease the two bearings located opposite the discharge duct. Bearings to be lubricated using high temperature grease.
4. Lubricate drive chain and sprockets with light grease/oil as necessary.
5. Check drive sprockets and chain for wear. Replace as required. Check and adjust drive chain tension as required.
6. Check hose reel mounts for cracked or loose bolts. Tighten or replace as required.
7. Check up/down switch for proper operation. Make sure mounting bolts are tight. Make sure electrical connections are tight.
8. Inspect the flexible hose for damage and/or water. Replace hose as required.

IMPORTANT

Oversized Motorized Hose Reel Mounting Instructions

Hose reel must be mounted rigid to building structural members.

1/2" Mounting hardware to be a minimum of grade 8 bolts, nuts, washers, and lock washers. Mounting hardware is not included.

Hanging with threaded rod or other types of suspension hangers is not acceptable. This will cause the reel to sway when in operation and result in hanger stress and failure.

Mount the reel level and plumb and using all end and midpoint bolt holes.

XL Hose Reel Mounting Instructions

Support Steel At Each Reel "A" Frame Required

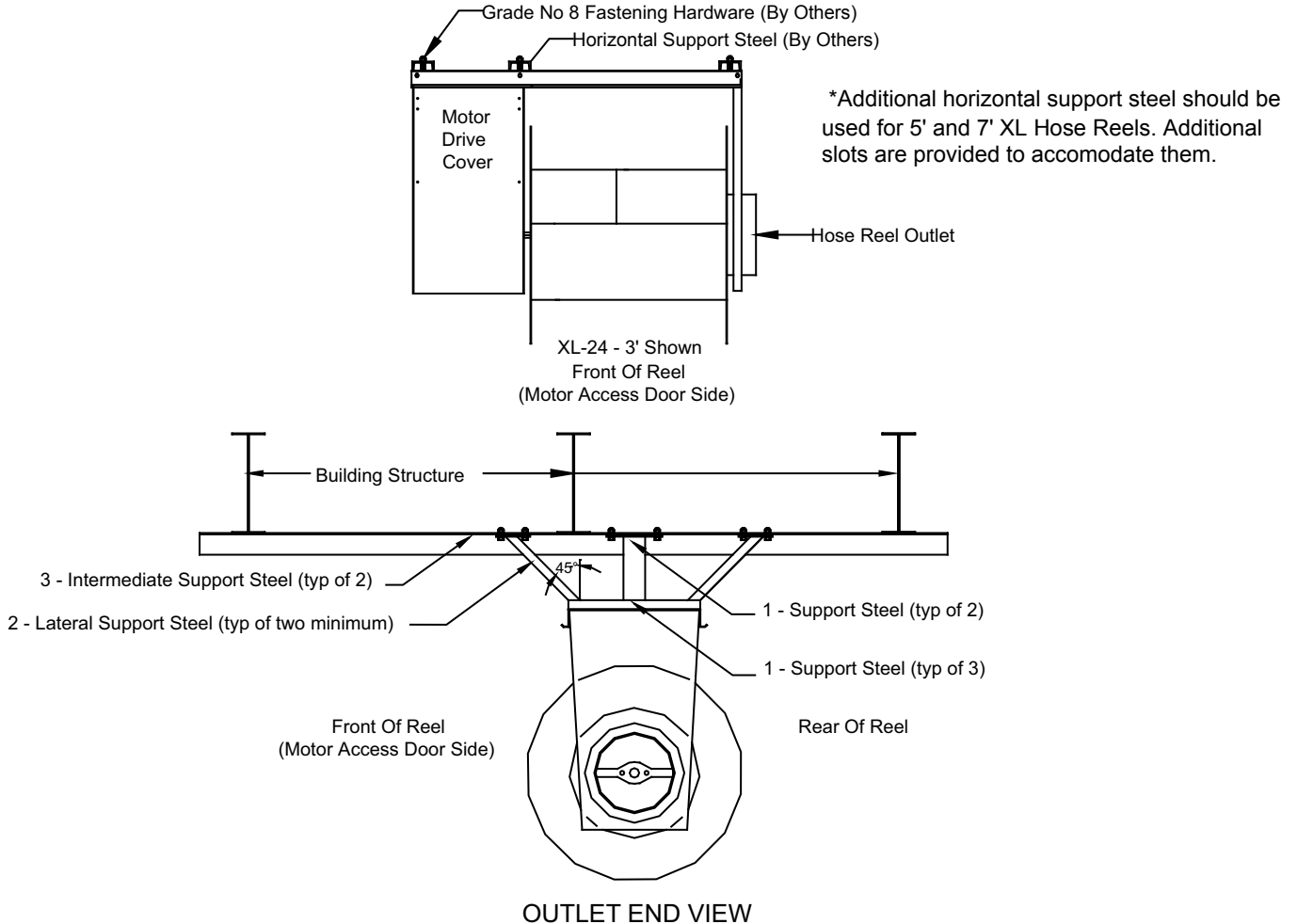

*Additional horizontal support steel should be used for 5' and 7' XL Hose Reels. Additional slots are provided to accommodate them.

The hose reel should be supported at each "A" frame with support steel bolted to the "A" frames. Fastening hardware should be Grade No 8, 1/2" minimum. Monoxivent does not make recommendations for the sizing of intermediate support steel or hose support steel due to the number of variables found in existing and new construction. Mounting height is determined by the limits of the rigid structural mounting frame assembly. Consult a structural engineer if necessary.

1. Support steel should provide a rigid mounting frame to building structure.
2. Lateral support steel provides control of torque movement upon start of the reel motor. Lateral support steel, at a minimum, should brace opposite corners, opposite sides. If torque is not adequately controlled, lateral bracing at all corners should be used with two at front and two at rear.
3. Where intermediate support steel is required, it is to be sized for the span based on hose reel weight, including hose and accessories and allow for the operating torque of motor and drum.

Hose Reel Hose Installation Procedure

1. Slide hose clamp over hose.



2. Slide hose over hose connection hub attached to reel. Make sure hose is fully engaged over hub.



Hose Reel Hose Installation Procedure

3. Slide clamp over hose/hose hub connection. Position clamp screw so that it is at either the 1:30 or 10:30 position relative to the top of the hose and securely tighten.



4. At approximately the 11:30 and 12:30 positions drill a 3/16" hole through the clamp, hose and hose connection hub.

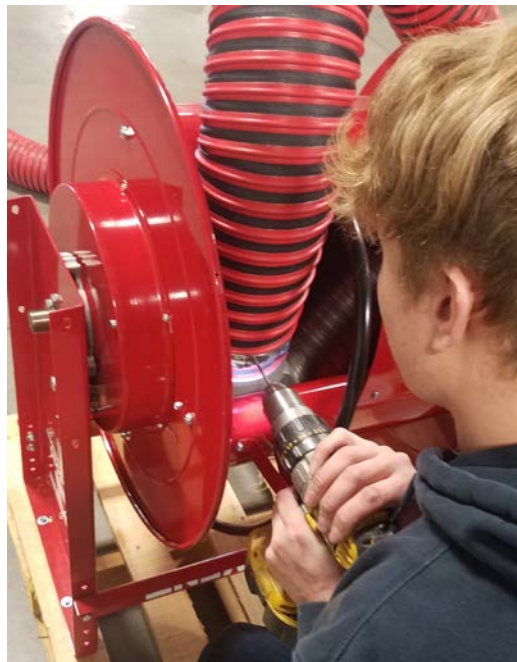

Hose Reel Hose Installation Procedure

5. Through the two holes drive 1/4" self-tapping screws through the clamp, hose and hose connection hub.



Note: On XL Series reels that incorporate 10" diameter through 18" diameter hose drill three 3/16" holes and screw three 1/4" self-tapping screws at approximately the 10:00 o'clock, 12:00 o'clock and 1:00 o'clock positions.

OPERATOR SPECIFICATIONS

MOTOR

TYPE: Continuous duty

HORSEPOWER:

Model J, H and HJ. 1/2, 3/4 HP

SPEED: 1725 RPM

VOLTAGE:

Model J, H and HJ. 115/230V 1 Phase
 208/230/460/575V 3 Phase

CURRENT (Amperage):

Models H, HJ, and J

Voltage-Phase	1/2 HP	3/4 HP
115-1Ø, 60Hz	11.2	13.6
230-1Ø, 60Hz	5.6	6.8
208/230-3Ø, 60Hz	3.1	4
460-3Ø, 60Hz	1.75	2
575-3Ø, 60Hz	1.4	1.6

ELECTRICAL

TRANSFORMER: 24Vac Secondary

CONTROL STATION: NEMA 2-Button Station
 Open/Close

WIRING TYPE: C2 (Standard)
 Constant pressure to OPEN and CLOSE

WIRING

WARNING

To reduce the risk of SEVERE INJURY or DEATH:

- ANY maintenance to the operator or in the area near the operator MUST NOT be performed until disconnecting the electrical power and locking-out the power. Upon completion of maintenance the area MUST be cleared and secured, at that time the unit may be returned to service.
- Disconnect power at the fuse box BEFORE proceeding. Operator MUST be properly grounded and connected in accordance with national and local electrical codes. The operator should be on a separate fused line of adequate capacity.
- ALL electrical connections MUST be made by a qualified individual.
- DO NOT install ANY wiring or attempt to run the operator without consulting the wiring diagram.
- ALL power wiring should be on a dedicated circuit and well protected. The location of the power disconnect should be visible and clearly labeled.
- ALL power and control wiring MUST be run in separate conduit.

POWER AND GROUND

Power and control wiring must be run in separate conduit in accordance with national and local electrical codes. Must use 14 AWG or heavier wire for power wiring. Use conduit knockouts for wiring as indicated on the electrical box labels.

- 1 Remove the operator cover.
- 2 Run power wires to electrical box according to national and local electrical codes.
ON THREE PHASE MACHINES ONLY: Incorrect phasing of the power supply will cause the motor to rotate in the wrong direction. To change motor rotation, exchange incoming power leads L1 and L2.

- 3 Attach power and ground wires to appropriate terminals.
IMPORTANT NOTE: This operator must be properly grounded. Failure to properly ground the operator could result in electric shock and serious injury.

POWER WIRING CHART	
DISTANCE	GAUGE
50 feet	14 AWG
100 feet	12 AWG
200 feet	8 AWG*
350 feet	6 AWG*
500 feet	4 AWG*
1000 feet	2 AWG*

* Maximum wire gauge that can be connected to the operator's terminal is 12 AWG. When a larger wire gauge is required, the wire must be gauged down to 12 AWG. USE COPPER WIRE ONLY.

NOTE: In some installations, such as a through-wall-installation, the rotation of the motor and logic board may have to be changed.

1. Locate the MOTOR DIRECTION jumper on the logic board. Remove jumper and relocate from STD to REV.
2. Relocate the safety limit switch (SLS) to the opposite side.
3. Remove CLOSE/OPEN decal and reattach appropriately.

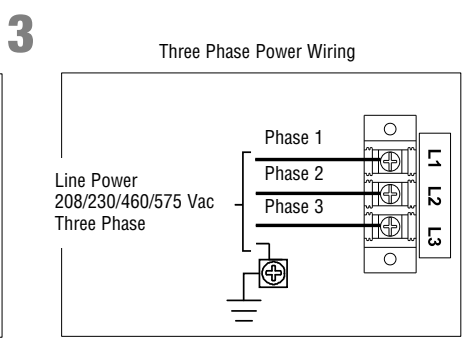
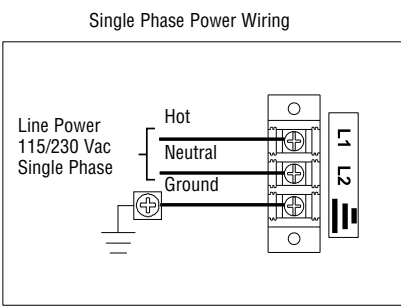
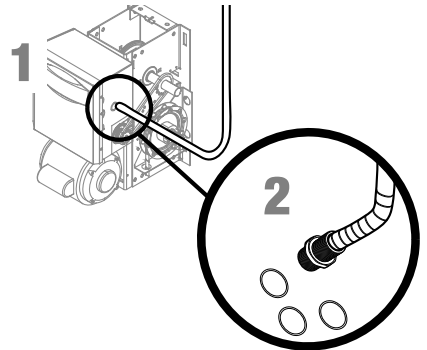

POWER WIRING
USE COPPER WIRE ONLY 40-10031B

NOTE: The low voltage control circuit wiring requires insulated, 20 AWG or greater wire. Refer to back page for additional control wiring.

- 1** Remove the control station cover.
- 2** Fasten the control station to the wall at least 5 feet above the ground. **The installation surface must be smooth and flat.** Attach the MAS label to the side of the control station.

- 3** Select appropriate knockout and run the wires to the operator.
- 4** Connect wires to the control station and replace the control station cover.

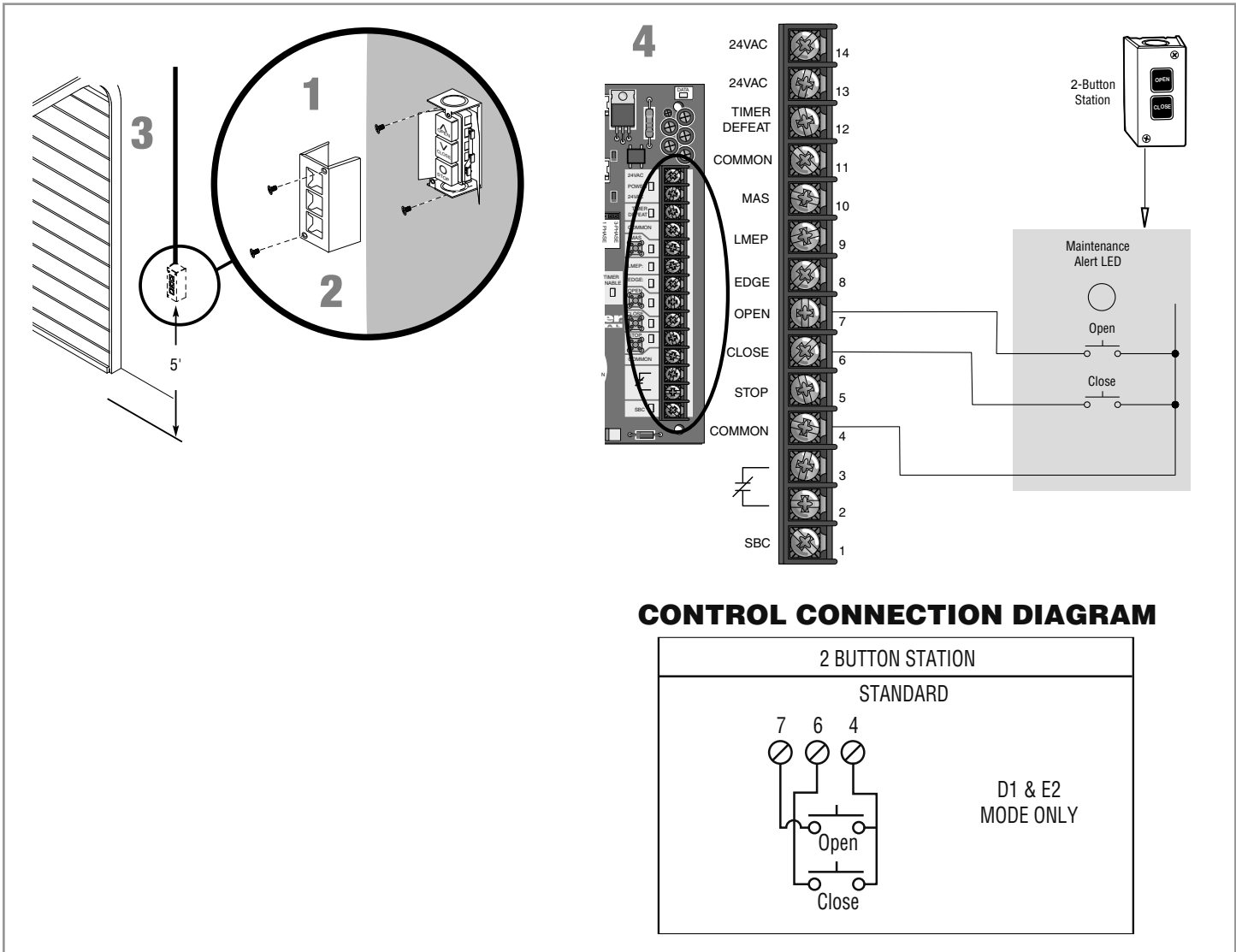

LIMIT ADJUSTMENT

- 1 Begin with the reel in the fully closed position to set the CLOSE limit.
- 2 Depress the retaining plate (1) and move the limit nut to the CLOSE limits (2).

NOTE: The Close Limit Switch (CLS) and Safety Limit Switch (SLS) LEDs on the logic board will illuminate when the switches are activated and the power is on.

- 3 When the retaining plate is released, verify that the retaining plate is fully seated with the notches of the limit nuts.
- 4 Open the reel to the fully open position and set the OPEN limit (3).

NOTE: The Open Limit Switch (OLS) LED on the logic board will illuminate when the switches are activated and the power is on.

- 5 When the retaining plate is released, verify that the retaining plate is fully seated with the notches of the limit nuts.

**CLUTCH ADJUSTMENT
(BELT DRIVE MODEL OPERATORS)**

- 1 Remove the cotter pin from the clutch nut on the clutch shaft.
- 2 Turn the clutch nut to release tension.
- 3 Re-tighten the clutch nut until there is just enough tension to permit smooth operation of the reel and to allow the clutch to slip if the reel is obstructed.
- 4 Secure the clutch nut with the cotter pin.

ADJUST TORQUE LIMITER CLUTCH (MODEL GT)

- 1 Loosen set screws of torque adjustment nut on the gear reducer.
- 2 Back off torque nut until there is very little tension on the belleville washers.
- 3 Tighten torque nut gradually until there is just enough tension to permit the operator to move the reel smoothly through a complete open/close cycle, but to allow the reducer to slip if the reel is obstructed.
- 4 Re-tighten the set screw that is directly over the flat portion of the shaft.



To avoid **SERIOUS** personal **INJURY** or **DEATH** from electrocution:
 • Disconnect electric power **BEFORE** performing **ANY** adjustments or maintenance.

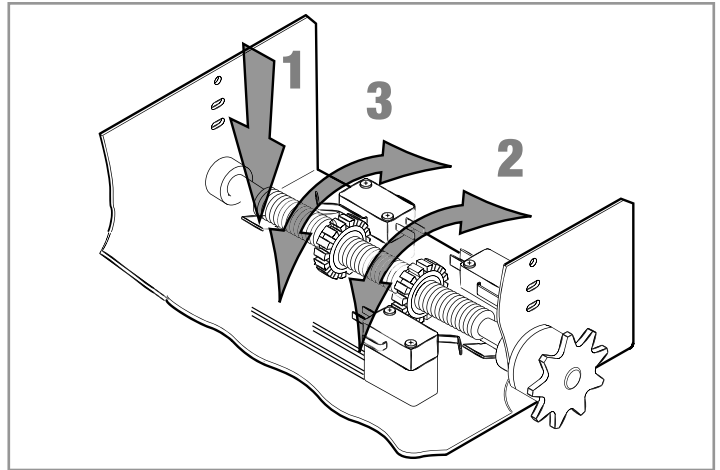

To avoid **SERIOUS** personal **INJURY** or **DEATH** from electrocution:
 • Disconnect electric power **BEFORE** performing **ANY** adjustments or maintenance.

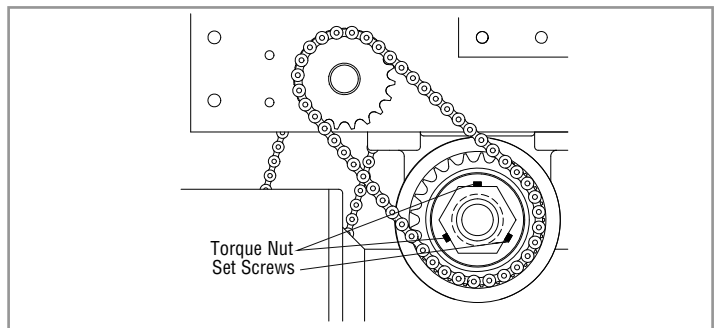
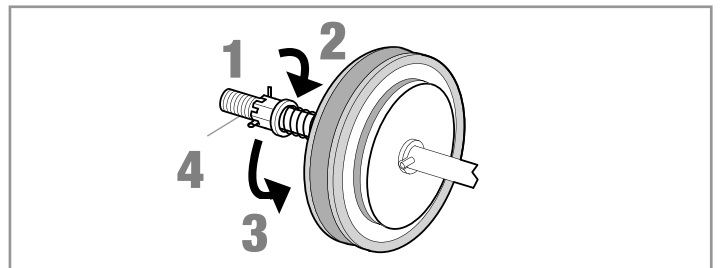

PROGRAMMING

INTRODUCTION TO PROGRAMMING

Many programmable functions require that a LiftMaster Entrapment Protection (LMEP) device be installed in order to function. Refer to the *Entrapment Protection* section.

LOGIC BOARD OVERVIEW

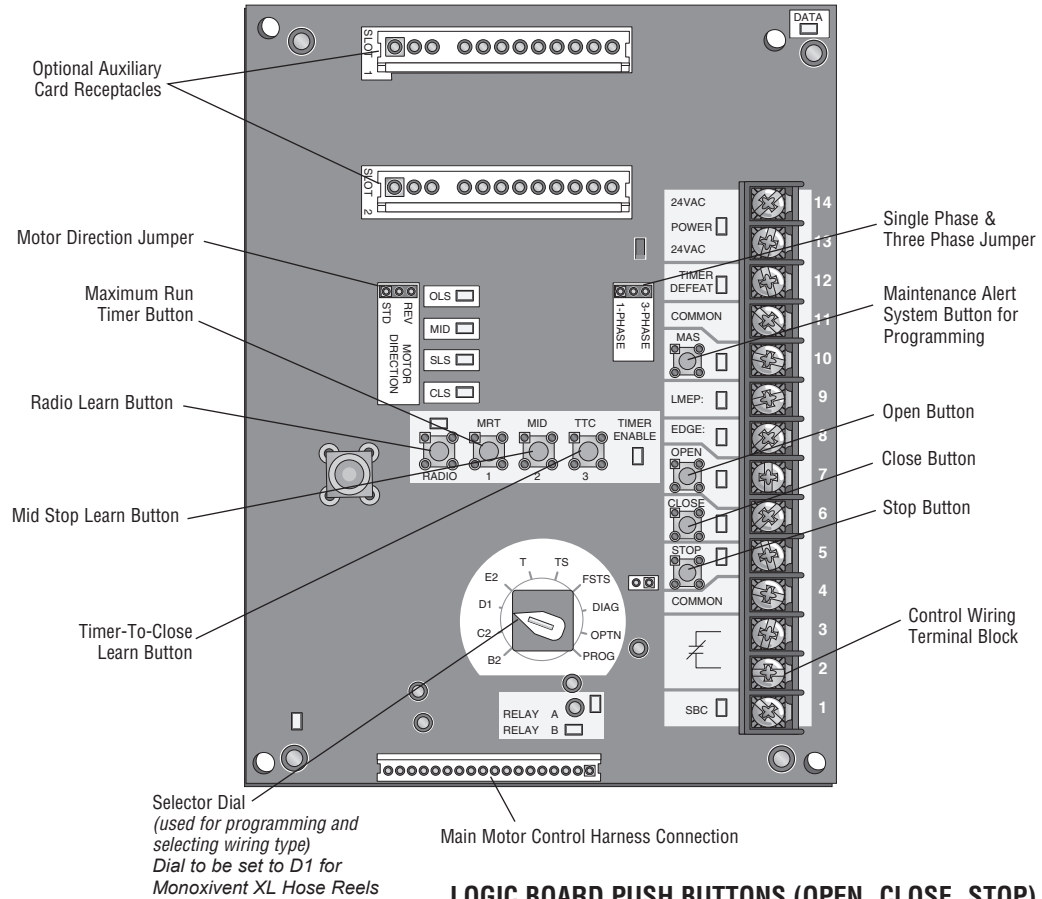

LOGIC BOARD LED OVERVIEW

NOTE: Before programming the logic board, set the operator's open and close limits. LEDs on the logic board are provided to assist setting the limits. As each limit is activated the corresponding LED will light up. The abbreviations are Open Limit Switch (OLS), Close Limit Switch (CLS) and Sensing Limit Switch (SLS). Refer to page 19 for limit switch adjustment instructions.

When power is applied to the operator, the following LED's will illuminate: STOP, CLOSE, OPEN, LMEP, 24Vac, RADIO, DATA, TIMER ENABLE, OLS MID, SLS, CLS, and MAS. Once the power up process is completed (approximately 2-3 seconds) only the appropriate LED's will continue to be lit (i.e., STOP, 24Vdc, limit LED(s) if limit(s) is activated).

LOGIC BOARD PUSH BUTTONS (OPEN, CLOSE, STOP)

Open, Close and Stop buttons are mounted directly on the logic board. Thus, making it easy to program as well as have reel control at the electrical box.

Either the stop control or a jumper MUST be wired between terminals 4 and 5 for the on board push buttons to function.

D1 Constant pressure to open and close with wiring for sensing device to stop. **Compatible with 2 or 3-Button Station.**

NOTE: When the power up process is over, the MAS LED will blink a code indicating the version of firmware. If the selector dial is in the DIAG, OPTN, or PROG position, the MAS will not provide this code. After the code has been provided the MAS LED will go out.

PROGRAMMING REMOTE CONTROLS

NOTE: The following programming requires a LiftMaster Monitored Entrapment Protection (LMEP) device. Your 315 MHz Security+® or dip switch remote control can be programmed to operate as a 3-button wireless control station: the large button will open the reel, the middle button will close the reel, and the third button will stop the door's movement. You may set up this feature as follows:

1. To enter programming press and release the RADIO button on the logic board (the RADIO LED will light).
2. To program the OPEN button to a remote control press and release the OPEN button on the logic board. The RADIO LED will flash and then stay on solid. Then press the corresponding button on the remote control. The RADIO LED on the logic board will flash, this confirms that the remote control has been programmed. (By programming the remote you use 1 channel of the 23 channels on the radio receiver.)
3. To program the CLOSE button to a remote control press and release the CLOSE button on the logic board. The RADIO LED will flash and then stay on solid. Then press the corresponding button on the remote control. The RADIO LED on the logic board will flash, this confirms that the remote control has been programmed. (By programming the remote you use 1 channel of the 23 channels on the radio receiver.)
4. To program the STOP button to a remote control press and release the STOP button on the logic board. The RADIO LED will flash and then stay on solid. Then press the corresponding button on the remote control. The RADIO LED on the logic board will flash, this confirms that the remote control has been programmed. (By programming the remote you use 1 channel of the 23 channels on the radio receiver.)
5. After learning remote controls press the RADIO button on the logic board (RADIO LED will turn off). **NOTE:** If no activity within 30 seconds the radio will automatically exit programming mode.

REMOTE CONTROL PROGRAMMING FEATURE

Program Remote Controls from the 3-button control station (3BCS).

This feature allows the user to add additional remote controls from the 3BCS. By default the remote control learn option is off. **NOTE:** Requires access to the operator electrical box to enable or disable this feature.

To turn this feature on:

1. Turn the SELECTOR DIAL to PROG.
2. Press and release the RADIO button. The RADIO LED will be lit.
3. Press and release the MID button. The RADIO LED will flash quickly 6 times.
4. Press and release the RADIO button. The RADIO LED will turn off.
5. Return the SELECTOR DIAL to the desired wiring type.

To add remote controls from the 3BCS:

1. With the door in the fully closed position (close limit activated), press and hold STOP.
2. While holding STOP, press and hold CLOSE.
3. While holding STOP and CLOSE, press and hold OPEN.
4. Release all three buttons once the MAS LED has lit.
5. Learn a remote control by one of the following methods:
 - a. Programming a **standard single button/single function remote control**, push and hold the remote control button until the MAS LED goes out. Repeat steps 1 through 4 to add additional remote controls.
 - b. Programming a **3-button/three function remote control** (OPEN/CLOSE/STOP), first push the button on the 3BCS (Example: OPEN) and then press and hold the button on the remote control (Example: large button) that you want to correspond with the selected (Example: OPEN) command until the MAS LED flashes and goes out. Repeat steps 1 through 4 to add additional buttons (CLOSE AND STOP).

To turn this feature off:

1. Turn the SELECTOR DIAL to PROG.
2. Press and release the RADIO button. The RADIO LED will be lit.
3. Press and release the MRT button. The RADIO LED will flash quickly 3 times.
4. Press and release RADIO button. The RADIO LED will turn off.
5. Return SELECTOR DIAL to desired wiring type.

NOTE: Restoring the operator to Factory Default (see **RESETTING FACTORY DEFAULTS**) will also disable this feature. The remote controls will still be learned.

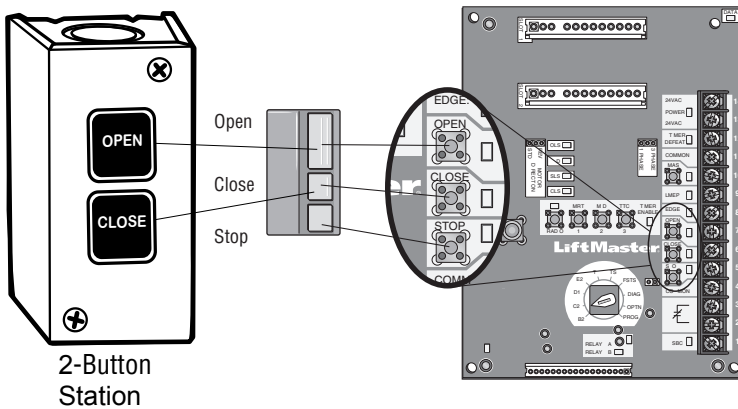

MAINTENANCE

MAINTENANCE SCHEDULE

For use with Maintenance Alert System.
Check at the intervals listed in the following chart:

ITEM	PROCEDURE	EVERY MONTH	WARNING		
			EVERY 3 MONTHS OR 5,000 CYCLES	EVERY 6 MONTHS OR 10,000 CYCLES	EVERY 12 MONTHS OR 20,000 CYCLES
Drive Chain	Check for excessive slack. Check and adjust as required. Lubricate.		●●		
Sprockets	Check set screw tightness.		●		◆
Clutch	Check and adjust as required.			●	◆
Belt	Check condition and tension.			●	◆
Fasteners	Check and tighten as required.			●	◆
Manual Disconnect	Check and operate.			●	◆
Bearings and Shafts	Check for wear and lubricate.		●●		
LiftMaster Monitored Entrapment Protection (LMEP)	Check alignment and functionality.	●			

◆ **Use SAE 30 Oil (Never use grease or silicone spray).**

- Do not lubricate motor. Motor bearings are rated for continuous operation.
- Do not lubricate clutch or V-belt.

◆ **Repeat ALL procedures.**

- Inspect and service whenever a malfunction is observed or suspected.

LIFE OF OPERATOR FEATURE (ODOMETER/CYCLE COUNTER)

The operator is equipped with an odometer to show how many months and cycles the operator has performed from the time it as installed. This feature can help determine how long the operator has been in service.

1. Start with the reel in the closed position.
2. Turn the SELECTOR DIAL to DIAG (diagnostic mode).
3. Press and release the MAS button on the logic board.
4. Press and release the MRT button on the logic board.
5. The open and close lights will flash. OPEN for every 5,000 cycles and CLOSE for every 3 months.
6. Return the SELECTOR DIAL to the desired wiring type.

NOTE: If the operator has not reached 5,000 cycles or 3 months, there will be no indications.

BRAKE (IF PRESENT)

A solenoid brake is available as an option for some models. The brake is adjusted at the factory and should not need additional adjustment for the life of the brake assembly.

Inspect the brake pad and replace brake assembly when necessary.

NOTE: Your operator may look different than the operator shown.

⚠ ⚠

To avoid **SERIOUS** personal **INJURY** or **DEATH**:

- Disconnect electric power **BEFORE** performing ANY adjustments or maintenance.
- ALL maintenance **MUST** be performed by a trained systems technician.

HOW TO ORDER REPAIR PARTS

OUR LARGE SERVICE ORGANIZATION SPANS AMERICA

Installation and service information are available.
Call our TOLL FREE number:

1-800-528-2806

www.liftmaster.com

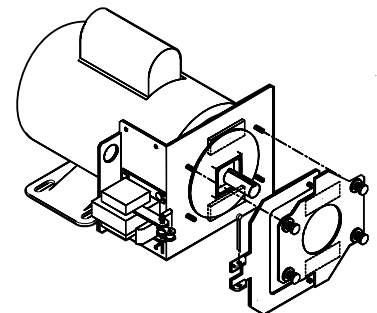

TROUBLESHOOTING

DIAGNOSTIC CHART

The logic board has several LEDs to assist in the installation and troubleshooting of the operator. The following chart should assist in verifying the operator is functioning properly. Turn the selector dial to DIAGNOSTIC to keep the reel from moving while troubleshooting.

LED	COLOR	
Power	Green	Indicates that power is being generated for the logic board.
Stop	Green	Indicates a closed circuit between common and terminal 5. Pressing stop should turn off this LED.
Open	Yellow	Indicates a closed circuit between common and terminal 7. Pressing the open button should turn ON this LED.
Close	Yellow	Indicates a closed circuit between common and terminal 6. Pressing the close button should turn ON this LED.
LMEP	Green	Solid on indicates photoelectric sensors learned. Flashing indicates photoelectric sensors need to be connected or obstructed**. Solid off indicates no sensors learned.
Timer Defeat	Yellow	Solid on indicates a closed circuit between common and terminal 12. Timer-To-Close will not close.
OLS	Yellow	Pressing the Open Limit Switch should turn ON this LED.
CLS	Yellow	Pressing the Close Limit Switch should turn ON this LED.
SLS	Yellow	Pressing the Sensing Limit Switch should turn ON this LED.
Edge	Yellow	Indicates a closed circuit between common and terminal 8. Pressing the edge should turn ON this LED.
Mid Stop	Yellow	Solid on indicates reel is stopped on up or down mid stop. Flashing indicates MID STOP is being set.
Timer Enabled	Green	Solid on indicates TIMER is programmed and will activate from open or mid stop position. Flashing indicates Timer is counting down and reel will close after preset time.
SBC	Yellow	Indicates a closed circuit between common and terminal 1. Pressing the single button control station should turn ON this LED.
MAS	Yellow	Indicates the Maintenance Alert System has been activated or an error code has been triggered.
Relay A	Yellow	Indicates open or close command has been given to the motor. LED turns on when OPEN/CLOSE button is pressed.
Relay B	Yellow	Indicates open or close command has been given to the motor. LED turns on when OPEN/CLOSE button is pressed.
DATA	Green	Indicates communication between the Logic 4 board and optional TLSCARD.

** RESTRICTED CLOSE. This method will allow you to close the reel when LMEP device(s) are no longer working. Press and hold the CLOSE button until the reel reaches the closed limit. If the CLOSE button is released before the reel reaches the closed limit the operator will stop and the procedure will need to be repeated to fully close the reel.

FAULT

THE OPERATOR WILL NOT RESPOND TO ANY COMMANDS

POSSIBLE CAUSE

- a) No power supply
- b) Operator control station is wired wrong
- c) Interlock switch is activated
- d) Dial still in programming, option, or diagnostic mode
- e) Motor is malfunctioning
- f) Motor thermal overload tripped
- g) Possible accessory malfunction
- h) Off Board relay may need to be replaced see wiring diagram
- i) Possible logic board failure

FIX

- Verify primary line voltage from power source. Green POWER LED must be on.
- Use the OPEN, CLOSE and STOP LEDs to help check correct wiring. Verify that the board is accepting commands by using the onboard station. Green LED next to stop button must be on.
- Check Interlock(s). If more than one external interlock is present they must be wired in series. Green LED next to stop button must be on.
- Set dial to desired wiring type.
- Verify proper voltage getting to the motor (Check motor name plate).
- Check to see if motor is hot. Allow motor to cool before attempting to move reel. Cycle operator in constant pressure one full cycle open and close to reset fault.
- Disconnect all devices, reattach them one at a time testing for a failure after each one is replaced.
- When the OPEN or CLOSE button is pressed, Relay A or B LED should turn on and the reel should move in the corresponding direction. If Relay A or B lights and the reel does not move, off board relay may need to be replaced (see wiring diagram Off Board Relays).
- Replace logic board.

POWER LED IS NOT ON

- a) Loose secondary wiring connections or a faulty control transformer
- b) Hoist interlock switch

- Repair or replace connections or control transformer.
- Check interlock. Verify the manual release chain is not engaged.

TROUBLESHOOTING ERROR CODES

Logic 4.0 operators incorporate a self diagnostic feature built into the MAS LED. In addition to indicating when routine maintenance is due, the MAS LED can be used to troubleshoot some problems with the operator.

If the MAS LED is flashing on and off rapidly, the Maintenance Alert System has been triggered and the schedule operator service is due. If the MAS LED flashes 2 or more pulses in a row followed

by a pause, an operator error has occurred. To view how many errors currently exist, turn the selector dial to DIAGNOSTIC and press the OPEN button. To read out each individual error code (if more than one exists) press CLOSE. It is possible to have more than one error at a time.

The chart below can assist with identifying the flashes on the MAS LED.

ERROR CODE	DISPLAY	DESCRIPTION	EFFECT	CORRECTION
E1	1 blink	MAS triggered (cycles or months)	None normal operation	Reset MAS (page 32).
E2	2 blinks	No RPM input during opening	The reel only responds to constant pressure commands	Clutch is slipping, adjust clutch, or verify RPM sensor connection or replace RPM sensor. NOTE: To relearn the RPM sensor, move the reel with a constant pressure command. The reel will stop once relearned and normal operation will resume.
E3	3 blinks	(MRT) Maximum Run Time timed out	The reel stops before reaching set open or close limit(s)	First check Operator for any faults (i.e., Bad Limit switch), manually learn Max Run Timer (page 35) OR reset factory defaults (page 35).
E4	4 blinks	Obstruction sensed on closing	Operator will reverse to OPEN position	Cleared by removing obstruction or realigning photoelectric sensors and giving a close command.
E5	5 blinks	Stuck button pressed for greater than 2 minutes	Stuck button on 3-button station will not respond	Stuck button must be unstuck before it will be recognized as an input.
E6	6 blinks	Invalid option card plugged into option card receptacles	Option card will not function properly	Refer to accessories page for list of supported option card(s).
E7	7 blinks	LiftMaster Monitored Entrapment Protection (LMEP) device faulted or removed for greater than 2 minutes	Normal operation (5 second constant pressure override required to close)	Cleared when safety device is cleared or connected.
E8	8 blinks	Brownout Detected	Operator will run as long as enough power is present	1. Check AC line for voltage. 2. Check transformer secondary for low voltage. Too many accessories may be connected to the transformer.
E9	Flash on start of movement	Motor movement at invalid time	Operator will continue to function normally for 5 operations and then default to a constant pressure mode	Check relays and the drive circuitry to ensure that they are turning off. Operator must know that they are turning off. Operator must run correctly for two starts for the error to be cleared.
E10	10 blinks	Motor Phase Jumper changed while unit is not in programming mode	The phase will not change	Enter programming mode and move phase jumper to change phase.

NOTE: Error codes take priority over normal MAS LED operation. Error codes will repeat on the MAS every 1.5 seconds until cleared. There may be more than one error present, but only the highest priority will flash. If the highest error is cleared, the next highest will flash. All errors self-correct when the corrective action is taken and a reset is not needed.

TROUBLESHOOTING RADIO FUNCTIONALITY

The error codes will display at the radio LED.

NOTE: Radio receiver is compatible with 315 MHz remotes.

ERROR CODE	DISPLAY	SYMPTOM	POSSIBLE PROBLEM	CORRECTION
R1	Quick Flash	No response from the remote	Unlearned remote - A user tries to use a remote, but the RADIO LED only flashes briefly and there is no response from the operator.	Try re-learning the remote (page 30).
R2	No LED activity	No response from the remote	Cannot recognize remote - A weak signal caused by a discharged battery or outside interference with the remote(s) - OR - the remote(s) being learned is not compatible with the operator. Antenna not installed or damaged.	Replace battery - OR - eliminate interference - OR - obtain a qualified remote - OR - check antenna connections.
R3	Radio LED turns off after 30 seconds	The remote cannot be learned	Cannot recognize remote - A weak signal caused by a discharged battery or outside interference interfering with the learn process - OR - the remote(s) being learned is not compatible with the operator. Antenna not installed or damaged.	Replace battery - OR - eliminate interference - OR - obtain a qualified remote - OR - check antenna connections.
R4	2 blinks	The remote cannot be learned	Receiver memory full - A user enters RADIO function learning mode but there is no space left to add another remote.	Erase all learned remotes and re-learn the desired remote.
R5	3 blinks	The remote cannot be learned	Duplicate remote - A user enters RADIO function learning and selects the function to be learned. When the remote button is pressed for learning, a search reveals that remote is already learned.	This remote already has a function associated with it. To change the function, erase all learned remotes and re-learn the desired remote.
R6	LMEP LED flashes	Cannot close via constant pressure in C2, D1 or E2 modes.	No safety device present - A safety device is required to close via constant pressure.	Must connect a LiftMaster Monitored Entrapment Protection (LMEP) device.

XL Hose Reel
WIRING DIAGRAMS
LOGIC (VER. 5.0) 1 PHASE WIRING DIAGRAM

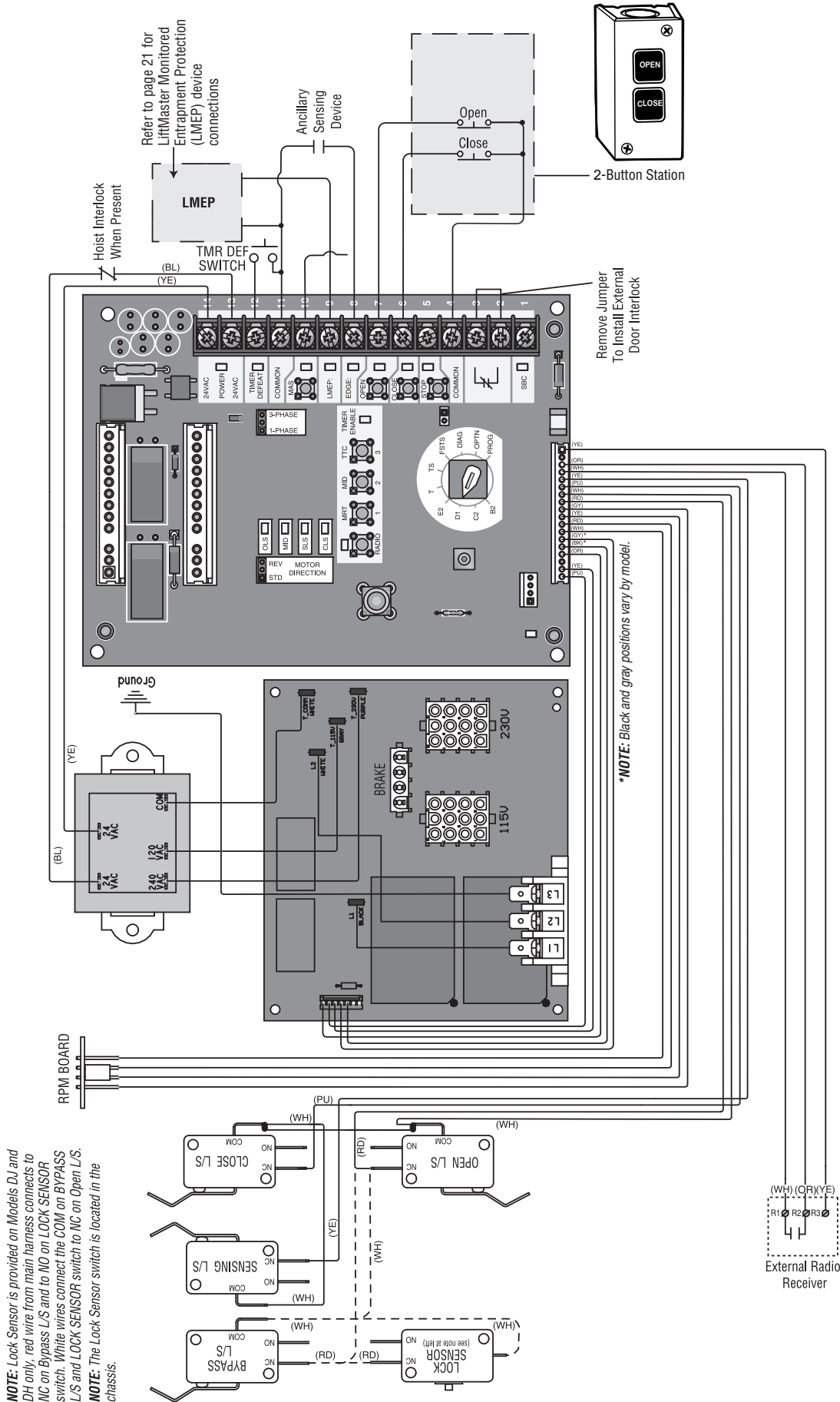

NOTE: Lock Sensor is provided on Models D1 and D1H only. red wire from main harness connects to NC on Bypass L/S and NO on LOCK SENSOR switch. White wires connect the COM on BYPASS L/S and LOCK SENSOR switch to NC on Open L/S. **NOTE:** The Lock Sensor switch is located in the chassis.

NOTE: 32 Vdc power supplied from White and Yellow wires located within the electrical box.

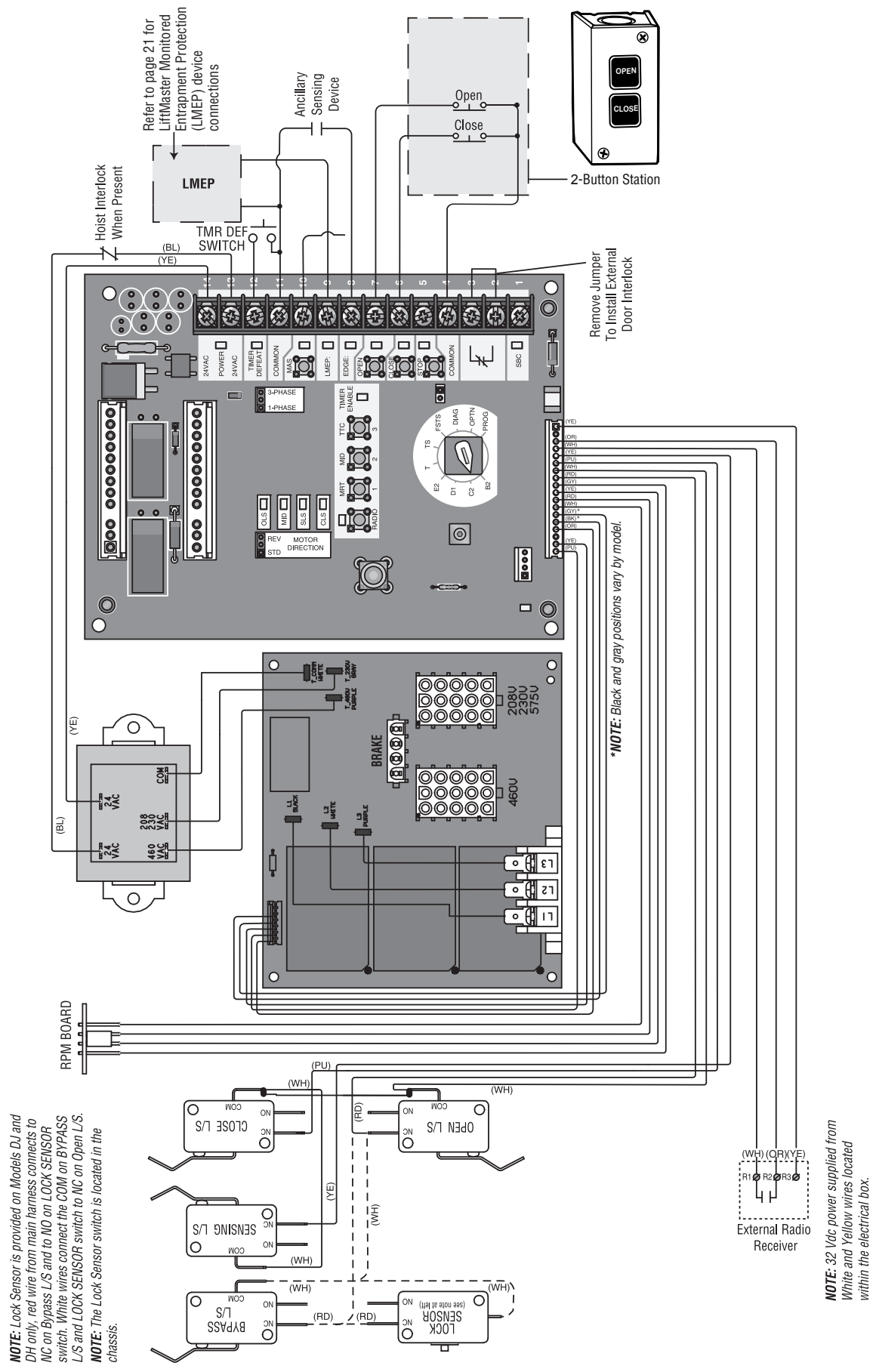

NOTE: Lock Sensor is provided on Models DJ and DH only, red wire from main harness connects to NC on Bypass L/S and to NO on LOCK SENSOR switch. White wires connect the COM on BYPASS L/S and LOCK SENSOR switch to NC on Open L/S.

NOTE: The Lock Sensor switch is located in the chassis.

NOTE: 32 Vdc power supplied from White and Yellow wires located within the electrical box.