

**TECHNICAL  
INFORMATION**

In the interest of continuing product improvement, we reserve the right to change models, specifications, and/or features without prejudice.

PROJECT: \_\_\_\_\_  
 LOCATION: \_\_\_\_\_  
 ARCHITECT: \_\_\_\_\_  
 ENGINEER: \_\_\_\_\_  
 CONTRACTOR: \_\_\_\_\_  
 DATE: \_\_\_\_\_ SALES ENGINEER: \_\_\_\_\_

**XL Series Hose Reels - Oversized • 24" Drum Diameter - 7' Drum Width (XL-24-7)**

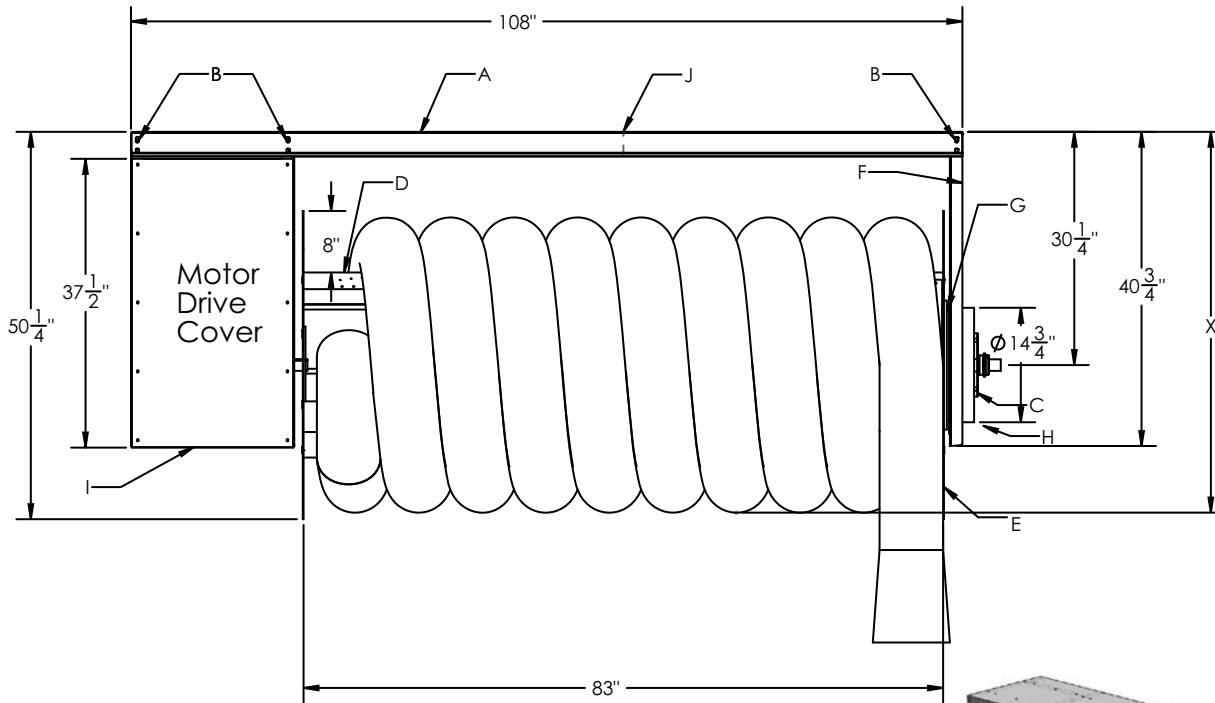

**XL-24-7 MONOXIVENT  
ID/DESCRIPTION**

- A. Support Frame
- B. 5/8" mounting holes through A frame and base plate/location for hanger channels
- C. Bearing
- D. 16-Gauge Dr
- E. 12-Gauge Drum Ends
- F. 10-Gauge End Frame
- G. Interior outlet bearing sleeve
- H. Inner, Outer Ring Outlet
- I. 18-Gauge Motor Cover
- J. Mid point hanger channel location

**X Dimension (Nominal ID):**

- 8" diameter hose = 51"
- 10" diameter hose = 53"
- 12" diameter hose = 55"

\* Note #1: The outside dimension, for the Nominal Hose ID, may vary - please consult factory.

\* Note #2: Nominal dimensions, without allowances for materials to hang and support hose reels.

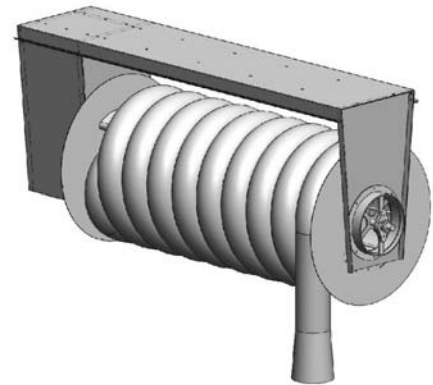

**NOTES:**

- XL-24-7: Weight - 680 lbs.
- \* Operator - Standard: 1/2 HP 115/230/1 or Optional: 1/2 HP 230/460/3 Chain Driven ODP Motor Assembly, 2-button Up/Down Switch, and Internal Automatic Reset Thermal Overload
- Optional: Explosion Proof Motor Drive with Push Button Control
- Hose Reel shall be powder-coated Red (optional Stainless Steel Construction)
- Contact Factory for Flex Hose Options



**24" DRUM WIDTH • CAPACITIES**

Model	Drum Dia.	Drum W.	Hose Dia.	Hose Capacity
XL-24-7	24"	7'	8"	Up to 95'
	24"	7'	10"	Up to 85'
	24"	7'	12"	Up to 75'