

**TECHNICAL
INFORMATION**

In the interest of continuing product improvement,
we reserve the right to change models,
specifications, and/or features without prejudice.

PROJECT: _____
 LOCATION: _____
 ARCHITECT: _____
 ENGINEER: _____
 CONTRACTOR: _____
 DATE: _____ SALES ENGINEER: _____



- 1 - Hose reel storage drum, w/30"x6" - Series 5000 Hose (other hose types available, contact factory)
- 2 - 6" Discharge hose connection with internal hose connecting to inlet bearing
- 3 - Spring cassette
- 4 - "A" frame
- 5 - 10" hard rubber wheel on 1/2" axle
- 6 - 10 ga connecting base plate
- 7 - Swivel caster with 5" hard rubber wheels
- 8 - Eliminator base with two side access doors
- 9 - Lower mast with locking "T" handle
- 10 - Upper mast - stored height 90", fully extended height 120"
- 11 - Fan inlet - Fan CFM Motor - 1.5 HP, 1 ph, 115 Volt, 3450 RPM
- 12 - Series 7600 high compression hose, 600 degrees
- 13 - 6", 1.5 center line, 20 ga elbow
- 14 - 20 ga rigid duct
- 15 - 8" transition and 45 degree nozzle
- 16 - Retractable cord reel mounted inside of cabinet includes cord & plug.
- 17 - Fan on/off switch
- 18 - "T" handle
- 19 - Inlet bearing
- 20 - Quick connect coupler. Allows for hose disconnect from mast to allow for under chassis use.

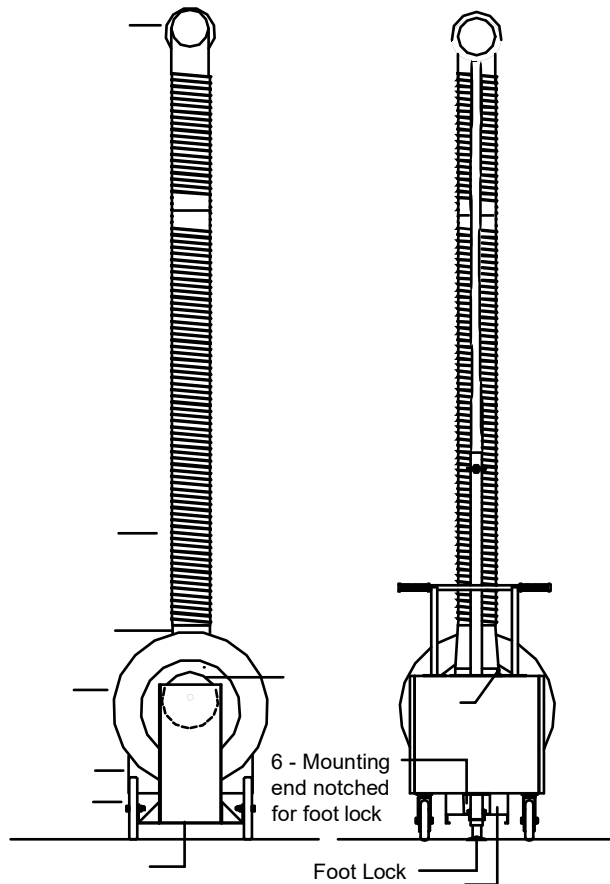

2006, Monoxivent All Rights Reserved
 Monoxivent - 1306 Mill Street, Rock Island, IL 61201
 www.monoxivent.com - Duplication, reproduction or
 redistribution in any way of this document or its contents
 without the expressed written approval of Monoxivent
 is strictly prohibited by law.

Blower Performance:

Model	HP	1"	2"	3"	4"	5"	6"	7"
D15	1.5	965	910	840	780	675	550	330

Standard Motors are Baldor with TEFC Enclosure. Standard Motors are UL UR Recognized as a component and CSA Certified in Canada.

The D Series fans are not UL Listed or CSA Certified as an assembly.

Motor specifications subject to change without notice.

The construction is Silumin (Silicon Aluminum Alloy) for the housing and the wheel.

Approx. Wt.- 520 lbs.