

**TECHNICAL
INFORMATION**

In the interest of continuing product improvement,
we reserve the right to change models,
specifications, and/or features without prejudice.

PROJECT: _____
 LOCATION: _____
 ARCHITECT: _____
 ENGINEER: _____
 CONTRACTOR: _____
 DATE: _____ SALES ENGINEER: _____

SERIES 15000 - HOSE DIAMETER: 6" or 8"

Wall/Column Mount Bracket Components:

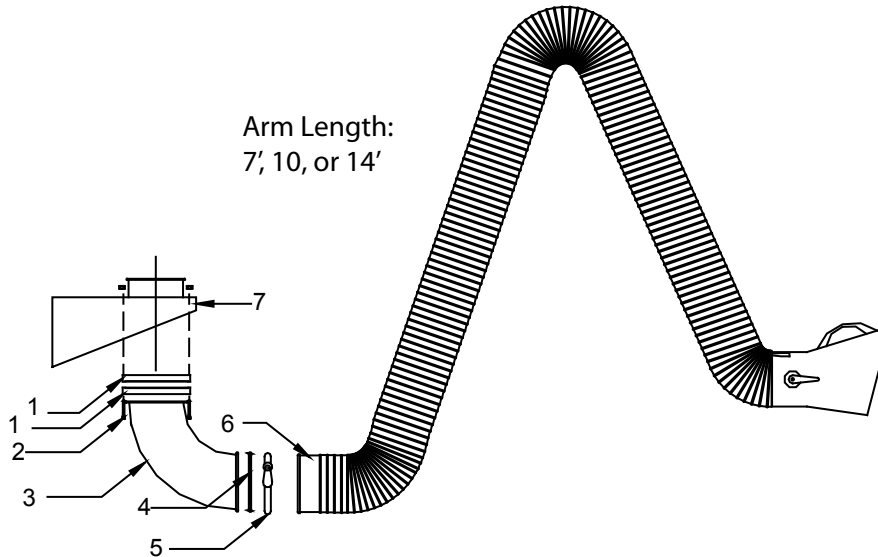

1. Swivel collar
2. Mounting bolts - through collar and attaches to wall bracket
3. Swivel flanged elbow
4. Flange gasket
5. Flange clamp
6. Internal arm mounting sleeve and pivot joint
7. Wall Bracket with flanged mounting collar (6" only)

Wall/Column Mount Bracket Dimensions - Side View (Below Left) and Back View (Below Right):

6" Wall Bracket

SIDE VIEW

BACK VIEW

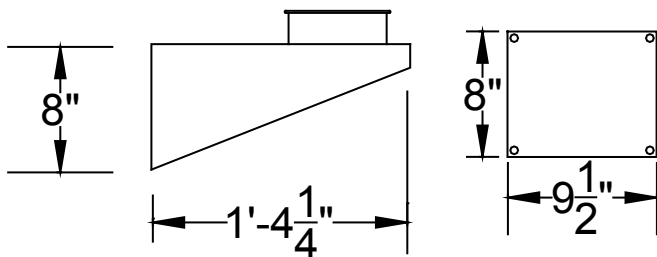

8" Wall Bracket

SIDE VIEW

BACK VIEW

