

**TECHNICAL  
INFORMATION**

In the interest of continuing product improvement,  
we reserve the right to change models,  
specifications, and/or features without prejudice.

PROJECT: \_\_\_\_\_  
 LOCATION: \_\_\_\_\_  
 ARCHITECT: \_\_\_\_\_  
 ENGINEER: \_\_\_\_\_  
 CONTRACTOR: \_\_\_\_\_  
 DATE: \_\_\_\_\_ SALES ENGINEER: \_\_\_\_\_

www.monoxivent.com

info@monoxivent.com

309-794-1000

Page: EF-12

- Wheel Diameter - 10"
- Wheel Type - Flatblade
- Tip Speed (FPM) = 2.62 x RPM
- Max. BHP = .018 x (RPM/1000)<sup>3</sup>
- Inlet Area - .61 Sq. Ft.
- Outlet Area - .57 Sq. Ft.
- Outlet Velocity (FPM) = CFM/.57
- Max. Mtr. Frame Size - 145T, Arr. 10
- Approx. Shipping Weight  
BI-60 - 173 lbs.

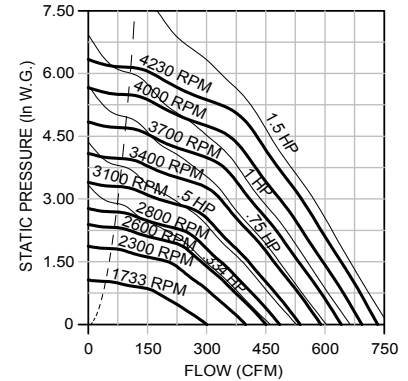
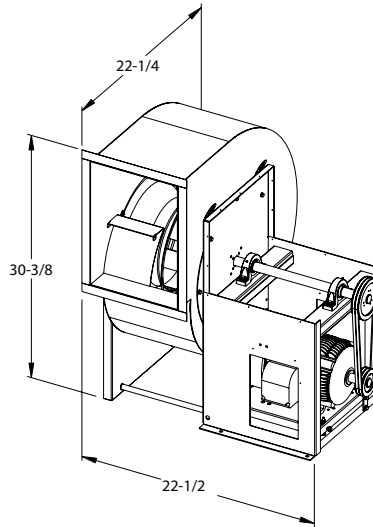

Do not select to left of dotted curve.

CFM	OV	1.000 SP		1.250 SP		1.500 SP		1.750 SP		2.000 SP		2.500 SP		3.000 SP		3.500 SP		4.000 SP		4.500 SP		5.000 SP	
		RPM	BHP	RPM	BHP	RPM	BHP	RPM	BHP	RPM	BHP	RPM	BHP	RPM	BHP	RPM	BHP	RPM	BHP	RPM	BHP	RPM	BHP
70	121	1733	.08																				
100	174	1785	.09	1976	.12	2148	.15	2306	.18	2453	.22												
130	226	1825	.10	2022	.13	2198	.17	2358	.20	2506	.24	2775	.32	3017	.41	3241	.50						
160	278	1867	.11	2058	.15	2236	.18	2400	.22	2551	.26	2825	.35	3070	.44	3295	.54	3502	.65	3697	.75	3881	.86
190	330	1950	.13	2111	.17	2276	.20	2437	.24	2588	.29	2867	.37	3117	.47	3344	.58	3554	.69	3751	.81	3936	.93
220	383	2069	.16	2208	.19	2346	.23	2487	.27	2629	.31	2903	.41	3155	.51	3386	.61	3600	.73	3799	.85	3986	.98
250	435	2190	.19	2330	.23	2455	.27	2574	.30	2696	.35	2946	.44	3192	.55	3423	.66	3638	.77	3840	.90	4030	1.02
280	487	2308	.22	2450	.27	2577	.31	2692	.35	2800	.39	3016	.49	3239	.59	3461	.71	3674	.83	3877	.95	4068	1.08
310	539	2433	.26	2568	.31	2697	.36	2815	.40	2922	.45	3119	.54	3314	.65	3514	.76	3716	.88	3914	1.02	4104	1.15
340	591	2567	.31	2692	.35	2815	.40	2933	.46	3043	.51	3239	.61	3418	.72	3595	.83	3777	.95	3961	1.08	4145	1.22
370	644	2708	.36	2824	.41	2939	.46	3051	.51	3161	.57	3362	.69	3538	.80	3703	.91	3865	1.03	4030	1.16	4199	1.30
400	696	2852	.42	2963	.47	3070	.52	3176	.58	3280	.64	3481	.76	3661	.89	3823	1.01	3976	1.13	4125	1.25		
430	748	2996	.49	3106	.54	3208	.60	3306	.65	3405	.71	3599	.84	3781	.98	3946	1.11	4097	1.24				
460	800	3141	.56	3249	.62	3349	.68	3444	.74	3536	.80	3720	.93	3898	1.07	4066	1.22	4220	1.36				
490	853	3288	.65	3394	.71	3493	.77	3585	.83	3674	.89	3846	1.03	4018	1.17	4184	1.33						
520	905	3437	.74	3540	.81	3637	.87	3728	.93	3815	1.00	3980	1.14	4142	1.29								
550	957	3588	.85	3687	.91	3783	.98	3872	1.05	3957	1.12	4117	1.26										
580	1009	3741	.96	3836	1.03	3929	1.10	4017	1.17	4101	1.25												
610	1061	3895	1.09	3987	1.16	4076	1.24	4163	1.31														
640	1114	4053	1.22	4139	1.30	4225	1.38																

Performance certified is for installation type B: Free inlet, Ducted outlet. Power rating (BHP) does not include transmission losses. Performance ratings do not include the effects of appurtenances (accessories).