

TECHNICAL INFORMATION

In the interest of continuing product improvement,
we reserve the right to change models,
specifications, and/or features without prejudice.

PROJECT: _____
LOCATION: _____
ARCHITECT: _____
ENGINEER: _____
CONTRACTOR: _____
DATE: _____ SALES ENGINEER: _____

www.monoxivent.com

info@monoxivent.com

309-794-1000

Page: EF-14

Wheel Diameter - 10"
Wheel Type - Flatblade
Tip Speed (FPM) = 2.62 x RPM
Max. BHP = .027 x (RPM/1000)³
Inlet Area - .61 Sq. Ft.
Outlet Area - .57 Sq. Ft.
Outlet Velocity (FPM) = CFM/.57
Max. Mtr. Frame Size - 145T, Arr. 10
Approx. Shipping Weight
BI-80 - 173 lbs.

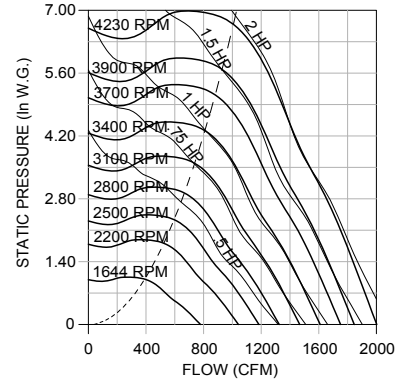
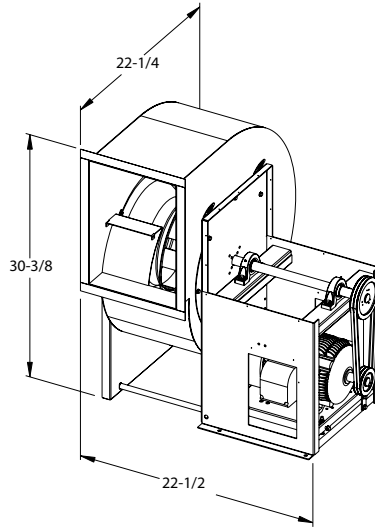

Do not select to left of dotted curve.

CFM	OV	1.000 SP		1.250 SP		1.500 SP		1.750 SP		2.000 SP		2.500 SP		3.000 SP		3.500 SP		4.000 SP		4.500 SP		5.000 SP	
		RPM	BHP	RPM	BHP	RPM	BHP	RPM	BHP	RPM	BHP	RPM	BHP	RPM	BHP	RPM	BHP	RPM	BHP	RPM	BHP	RPM	BHP
400	696	1644	.11																				
475	826	1717	.13	1860	.17																		
550	957	1819	.16	1943	.19	2067	.23	2191	.27														
625	1088	1940	.19	2050	.22	2158	.26	2267	.30	2376	.35												
700	1218	2064	.23	2171	.27	2269	.30	2366	.34	2464	.39	2658	.48	2852	.59								
775	1349	2186	.28	2296	.32	2391	.36	2481	.40	2569	.44	2744	.53	2920	.64	3096	.76						
850	1479	2304	.32	2418	.38	2516	.42	2604	.46	2687	.51	2848	.59	3008	.70	3168	.82	3328	.95	3488	1.08		
925	1610	2424	.37	2537	.43	2639	.49	2729	.54	2812	.59	2963	.68	3110	.77	3258	.89	3405	1.02	3552	1.16	3699	1.30
1000	1740	2548	.43	2655	.49	2758	.56	2852	.62	2936	.67	3086	.77	3225	.87	3361	.98	3497	1.10	3633	1.24	3769	1.38
1075	1871	2678	.49	2777	.55	2876	.62	2971	.69	3059	.76	3212	.88	3347	.98	3475	1.09	3602	1.20	3728	1.33	3855	1.48
1150	2002	2812	.57	2903	.63	2996	.70	3089	.77	3177	.85	3336	.99	3472	1.11	3597	1.22	3716	1.33	3835	1.45	3953	1.59
1225	2132	2950	.66	3035	.72	3121	.78	3209	.86	3295	.94	3456	1.10	3597	1.24	3722	1.36	3838	1.48	3950	1.60	4061	1.73
1300	2263	3090	.76	3170	.82	3250	.88	3333	.96	3415	1.04	3575	1.21	3719	1.37	3846	1.51	3963	1.64	4072	1.76	4178	1.89
1375	2393	3232	.86	3308	.93	3383	1.00	3460	1.07	3538	1.15	3693	1.32	3839	1.50	3970	1.67	4088	1.81	4196	1.95		
1450	2524	3376	.98	3449	1.05	3519	1.12	3592	1.19	3665	1.27	3813	1.44	3957	1.63	4091	1.82	4212	1.99				
1525	2654	3522	1.11	3590	1.18	3659	1.26	3727	1.33	3796	1.41	3935	1.58	4075	1.77	4209	1.97						
1600	2785	3667	1.25	3734	1.33	3800	1.41	3865	1.48	3929	1.56	4060	1.72	4195	1.92								
1675	2916	3814	1.40	3878	1.48	3941	1.57	4003	1.65	4065	1.73	4190	1.89										
1750	3046	3963	1.56	4025	1.65	4085	1.74	4145	1.82	4205	1.91												
1825	3177	4110	1.73	4169	1.83	4229	1.93																

Performance certified is for installation type B: Free inlet, Ducted outlet. Power rating (BHP) does not include transmission losses. Performance ratings do not include the effects of appurtenances (accessories).