

**TECHNICAL  
INFORMATION**

In the interest of continuing product improvement,  
we reserve the right to change models,  
specifications, and/or features without prejudice.

PROJECT: \_\_\_\_\_  
 LOCATION: \_\_\_\_\_  
 ARCHITECT: \_\_\_\_\_  
 ENGINEER: \_\_\_\_\_  
 CONTRACTOR: \_\_\_\_\_  
 DATE: \_\_\_\_\_ SALES ENGINEER: \_\_\_\_\_

www.monoxivent.com

info@monoxivent.com

309-794-1000

Page: EF-20

Wheel Diameter - 18"  
 Wheel Type - Flatblade  
 Tip Speed (FPM) = 4.71 x RPM  
 Max. BHP = .43 x (RPM/1000)<sup>3</sup>  
 Inlet Area - 2.03 Sq. Ft.  
 Outlet Area - 1.88 Sq. Ft.  
 Outlet Velocity (FPM) = CFM/1.88  
 Max. Mtr. Frame Size - 215T, Arr. 10  
 Approx. Ship Wt.  
 BI-180 - 396 lbs.

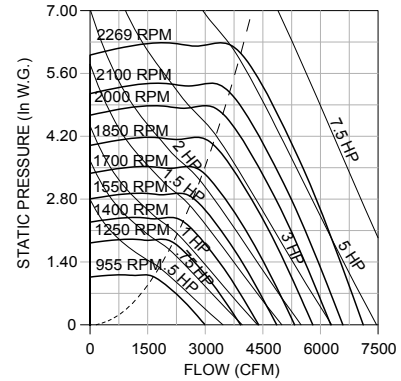
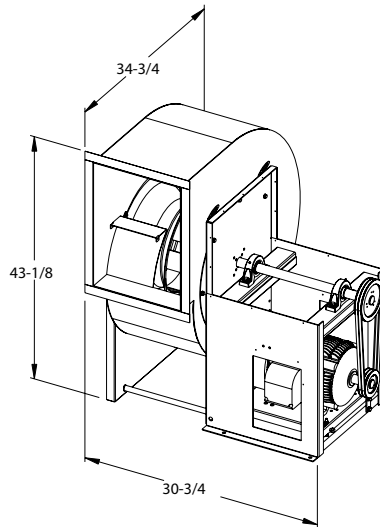

| CFM  | OV   | 1.000 SP |      | 1.250 SP |      | 1.500 SP |      | 1.750 SP |      | 2.000 SP |      | 2.500 SP |      | 3.000 SP |      | 3.500 SP |      | 4.000 SP |      | 4.500 SP |      | 5.000 SP |      |
|------|------|----------|------|----------|------|----------|------|----------|------|----------|------|----------|------|----------|------|----------|------|----------|------|----------|------|----------|------|
|      |      | RPM      | BHP  | RPM      | BHP  | RPM      | BHP  | RPM      | BHP  | RPM      | BHP  | RPM      | BHP  | RPM      | BHP  | RPM      | BHP  | RPM      | BHP  | RPM      | BHP  | RPM      | BHP  |
| 1800 | 957  | 955      | 0.39 | 1034     | 0.49 |          |      |          |      |          |      |          |      |          |      |          |      |          |      |          |      |          |      |
| 2100 | 1117 | 1015     | 0.48 | 1084     | 0.58 | 1152     | 0.68 |          |      |          |      |          |      |          |      |          |      |          |      |          |      |          |      |
| 2400 | 1276 | 1080     | 0.57 | 1145     | 0.68 | 1207     | 0.80 | 1267     | 0.92 | 1326     | 1.04 |          |      |          |      |          |      |          |      |          |      |          |      |
| 2700 | 1436 | 1150     | 0.69 | 1211     | 0.81 | 1270     | 0.93 | 1326     | 1.06 | 1380     | 1.19 | 1485     | 1.46 |          |      |          |      |          |      |          |      |          |      |
| 3000 | 1595 | 1222     | 0.82 | 1281     | 0.95 | 1337     | 1.09 | 1390     | 1.22 | 1441     | 1.36 | 1540     | 1.65 | 1634     | 1.95 | 1728     | 2.28 |          |      |          |      |          |      |
| 3300 | 1755 | 1298     | 0.98 | 1353     | 1.12 | 1406     | 1.26 | 1457     | 1.41 | 1507     | 1.56 | 1600     | 1.86 | 1689     | 2.18 | 1775     | 2.51 | 1861     | 2.86 |          |      |          |      |
| 3600 | 1914 | 1378     | 1.16 | 1429     | 1.31 | 1479     | 1.46 | 1527     | 1.61 | 1575     | 1.78 | 1665     | 2.10 | 1750     | 2.44 | 1831     | 2.78 | 1911     | 3.14 | 1989     | 3.51 | 2068     | 3.91 |
| 3900 | 2074 | 1458     | 1.36 | 1507     | 1.52 | 1554     | 1.68 | 1600     | 1.85 | 1645     | 2.02 | 1732     | 2.36 | 1814     | 2.72 | 1892     | 3.08 | 1968     | 3.45 | 2042     | 3.84 | 2114     | 4.24 |
| 4200 | 2234 | 1541     | 1.59 | 1587     | 1.76 | 1632     | 1.94 | 1675     | 2.11 | 1718     | 2.29 | 1801     | 2.65 | 1881     | 3.03 | 1957     | 3.41 | 2029     | 3.80 | 2100     | 4.20 | 2169     | 4.61 |
| 4500 | 2393 | 1626     | 1.85 | 1669     | 2.03 | 1711     | 2.21 | 1753     | 2.40 | 1794     | 2.59 | 1873     | 2.97 | 1949     | 3.36 | 2023     | 3.77 | 2094     | 4.18 | 2162     | 4.60 | 2228     | 5.02 |
| 4800 | 2553 | 1712     | 2.13 | 1753     | 2.33 | 1793     | 2.53 | 1832     | 2.72 | 1871     | 2.92 | 1947     | 3.33 | 2021     | 3.74 | 2092     | 4.16 | 2160     | 4.58 | 2227     | 5.03 |          |      |
| 5100 | 2712 | 1799     | 2.45 | 1838     | 2.66 | 1876     | 2.87 | 1913     | 3.07 | 1951     | 3.29 | 2023     | 3.71 | 2094     | 4.15 | 2162     | 4.58 | 2229     | 5.03 |          |      |          |      |
| 5400 | 2872 | 1886     | 2.80 | 1923     | 3.02 | 1960     | 3.24 | 1996     | 3.46 | 2032     | 3.69 | 2101     | 4.13 | 2168     | 4.58 | 2235     | 5.05 |          |      |          |      |          |      |
| 5700 | 3032 | 1974     | 3.18 | 2010     | 3.42 | 2045     | 3.65 | 2080     | 3.89 | 2114     | 4.12 | 2180     | 4.59 | 2245     | 5.06 |          |      |          |      |          |      |          |      |
| 6000 | 3191 | 2063     | 3.61 | 2097     | 3.85 | 2131     | 4.10 | 2164     | 4.35 | 2197     | 4.59 | 2261     | 5.09 |          |      |          |      |          |      |          |      |          |      |
| 6300 | 3351 | 2152     | 4.06 | 2186     | 4.33 | 2218     | 4.59 | 2250     | 4.85 |          |      |          |      |          |      |          |      |          |      |          |      |          |      |
| 6600 | 3510 | 2242     | 4.57 |          |      |          |      |          |      |          |      |          |      |          |      |          |      |          |      |          |      |          |      |