

**TECHNICAL  
INFORMATION**

In the interest of continuing product improvement,  
we reserve the right to change models,  
specifications, and/or features without prejudice.

PROJECT: \_\_\_\_\_  
 LOCATION: \_\_\_\_\_  
 ARCHITECT: \_\_\_\_\_  
 ENGINEER: \_\_\_\_\_  
 CONTRACTOR: \_\_\_\_\_  
 DATE: \_\_\_\_\_ SALES ENGINEER: \_\_\_\_\_

www.monoxivent.com

info@monoxivent.com

309-794-1000

Page: EF-23

Wheel Diameter - 22.5"  
 Wheel Type - Flatblade  
 Tip Speed (FPM) = 5.89 x RPM  
 Max. BHP = 1.57 x (RPM/1000)<sup>3</sup>  
 Inlet Area - 3.02 Sq. Ft.  
 Outlet Area - 2.94 Sq. Ft.  
 Outlet Velocity (FPM) = CFM/2.94  
 Max. Mtr. Frame Size - 215T, Arr. 10  
 Approx. Ship Wt.  
 BI-225 - 537 lbs.

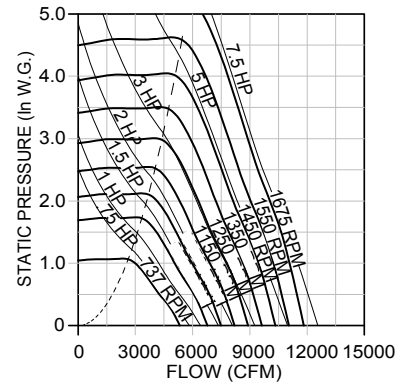
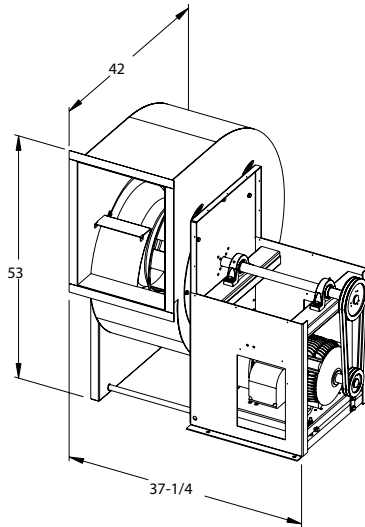

CFM	OV	1.000 SP		1.250 SP		1.500 SP		1.750 SP		2.000 SP		2.500 SP		3.000 SP		3.500 SP		4.000 SP		4.500 SP		5.000 SP	
		RPM	BHP	RPM	BHP	RPM	BHP	RPM	BHP	RPM	BHP	RPM	BHP	RPM	BHP	RPM	BHP	RPM	BHP	RPM	BHP	RPM	BHP
2850	969	737	0.61																				
3350	1139	775	0.73	835	0.90	895	1.08																
3850	1309	822	0.87	876	1.05	928	1.24	981	1.44	1033	1.66												
4350	1479	873	1.05	923	1.24	971	1.44	1018	1.65	1065	1.87	1157	2.33										
4850	1650	927	1.25	974	1.45	1020	1.67	1063	1.89	1106	2.12	1189	2.60	1272	3.12								
5350	1820	982	1.48	1028	1.71	1071	1.93	1113	2.17	1153	2.41	1230	2.91	1306	3.45	1381	4.01						
5850	1990	1037	1.74	1083	1.99	1125	2.24	1165	2.49	1203	2.74	1276	3.27	1347	3.82	1416	4.40	1484	5.00	1553	5.65		
6350	2160	1091	2.03	1139	2.31	1180	2.58	1219	2.85	1255	3.11	1325	3.66	1392	4.24	1457	4.84	1521	5.46	1584	6.11	1647	6.79
6850	2330	1145	2.35	1193	2.65	1236	2.95	1274	3.24	1310	3.53	1377	4.11	1441	4.71	1503	5.34	1563	5.98	1623	6.65		
7350	2500	1200	2.70	1247	3.03	1290	3.35	1329	3.67	1365	3.99	1430	4.60	1492	5.23	1552	5.89	1609	6.55	1666	7.24		
7850	2670	1256	3.08	1301	3.44	1344	3.79	1384	4.14	1420	4.48	1485	5.14	1545	5.80	1602	6.48	1658	7.18				
8350	2840	1315	3.52	1356	3.89	1398	4.27	1438	4.65	1475	5.02	1541	5.73	1600	6.43	1655	7.13						
8850	3011	1375	4.00	1413	4.38	1452	4.78	1492	5.19	1529	5.59	1596	6.36	1655	7.11								
9350	3181	1437	4.53	1471	4.92	1508	5.34	1546	5.77	1583	6.20	1651	7.03										
9850	3351	1499	5.11	1532	5.53	1566	5.96	1601	6.40	1637	6.85												
10350	3521	1565	5.78	1594	6.19	1625	6.63	1658	7.09														
10850	3691	1629	6.48	1656	6.90																		