

**TECHNICAL
INFORMATION**

In the interest of continuing product improvement,
we reserve the right to change models,
specifications, and/or features without prejudice.

PROJECT: _____
 LOCATION: _____
 ARCHITECT: _____
 ENGINEER: _____
 CONTRACTOR: _____
 DATE: _____ SALES ENGINEER: _____

www.monoxivent.com

info@monoxivent.com

309-794-1000

Page: EF-25

Wheel Diameter - 27"
 Wheel Type - Flatblade
 Tip Speed (FPM) = 7.07 x RPM
 Max. BHP = 3.90 x (RPM/1000)³
 Inlet Area - 4.35 Sq. Ft.
 Outlet Area - 4.23 Sq. Ft.
 Outlet Velocity (FPM) = CFM/4.23
 Max. Mtr. Frame Size - 256T, Arr. 10
 Approx. Ship Wt.
 BI-270 - 722 lbs.

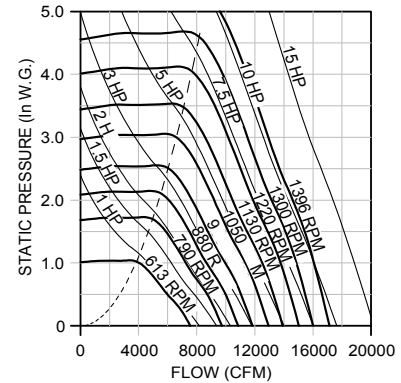
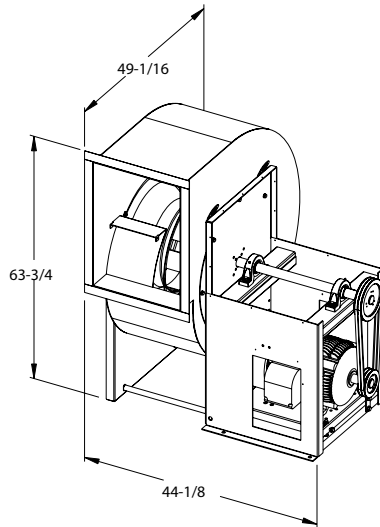

Do not select to left of dotted curve.

CFM	OV	1.000 SP		1.250 SP		1.500 SP		1.750 SP		2.000 SP		2.500 SP		3.000 SP		3.500 SP		4.000 SP		4.500 SP		5.000 SP	
		RPM	BHP	RPM	BHP	RPM	BHP	RPM	BHP	RPM	BHP	RPM	BHP	RPM	BHP	RPM	BHP	RPM	BHP	RPM	BHP	RPM	BHP
4050	956	613	.87																				
4650	1098	637	1.00	689	1.24																		
5250	1239	668	1.17	715	1.42	761	1.68	807	1.97														
5850	1381	702	1.36	746	1.62	788	1.90	830	2.20	871	2.51												
6450	1523	739	1.58	780	1.86	820	2.16	858	2.46	896	2.78	970	3.45										
7050	1665	776	1.83	816	2.13	854	2.44	890	2.76	925	3.08	994	3.78	1062	4.53								
7650	1806	815	2.11	854	2.43	890	2.76	924	3.09	958	3.44	1023	4.16	1086	4.92	1149	5.74						
8250	1948	853	2.41	892	2.77	927	3.12	960	3.47	992	3.83	1054	4.58	1114	5.37	1172	6.19	1231	7.07	1290	8.00		
8850	2090	891	2.75	930	3.13	965	3.51	997	3.88	1028	4.26	1087	5.03	1144	5.84	1200	6.70	1254	7.58	1309	8.52	1363	9.49
9450	2231	928	3.11	968	3.53	1003	3.93	1035	4.33	1065	4.73	1123	5.55	1177	6.38	1230	7.26	1282	8.17	1333	9.12	1384	10.10
10050	2373	966	3.50	1006	3.96	1041	4.39	1074	4.83	1103	5.24	1159	6.10	1212	6.98	1263	7.88	1312	8.81	1361	9.78		
10650	2515	1004	3.93	1043	4.41	1079	4.88	1112	5.35	1142	5.81	1196	6.69	1248	7.62	1297	8.55	1345	9.52				
11250	2656	1043	4.39	1081	4.91	1117	5.42	1150	5.91	1180	6.40	1234	7.34	1285	8.31	1332	9.26	1379	10.30				
11850	2798	1083	4.90	1119	5.44	1154	5.97	1188	6.52	1218	7.03	1273	8.04	1322	9.03	1369	10.00						
12450	2940	1125	5.46	1158	6.01	1192	6.58	1225	7.15	1256	7.70	1311	8.77	1360	9.82								
13050	3082	1168	6.08	1198	6.63	1230	7.22	1262	7.81	1293	8.40	1349	9.55										
13650	3223	1211	6.74	1239	7.31	1269	7.91	1300	8.53	1331	9.17	1387	10.40										
14250	3365	1255	7.45	1281	8.04	1309	8.66	1339	9.31	1368	9.95												
14850	3507	1300	8.24	1324	8.83	1350	9.46	1378	10.10														
15450	3648	1345	9.08	1368	9.69																		