

**TECHNICAL
INFORMATION**

In the interest of continuing product improvement,
we reserve the right to change models,
specifications, and/or features without prejudice.

PROJECT: _____
 LOCATION: _____
 ARCHITECT: _____
 ENGINEER: _____
 CONTRACTOR: _____
 DATE: _____ SALES ENGINEER: _____

**MNX-30SN90
with FT40E**

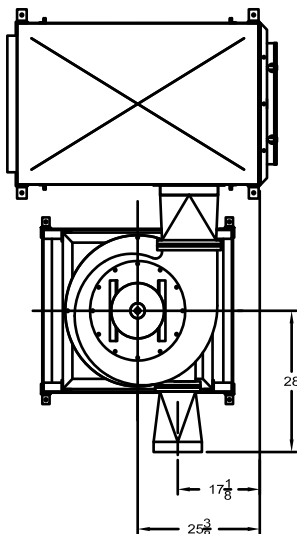
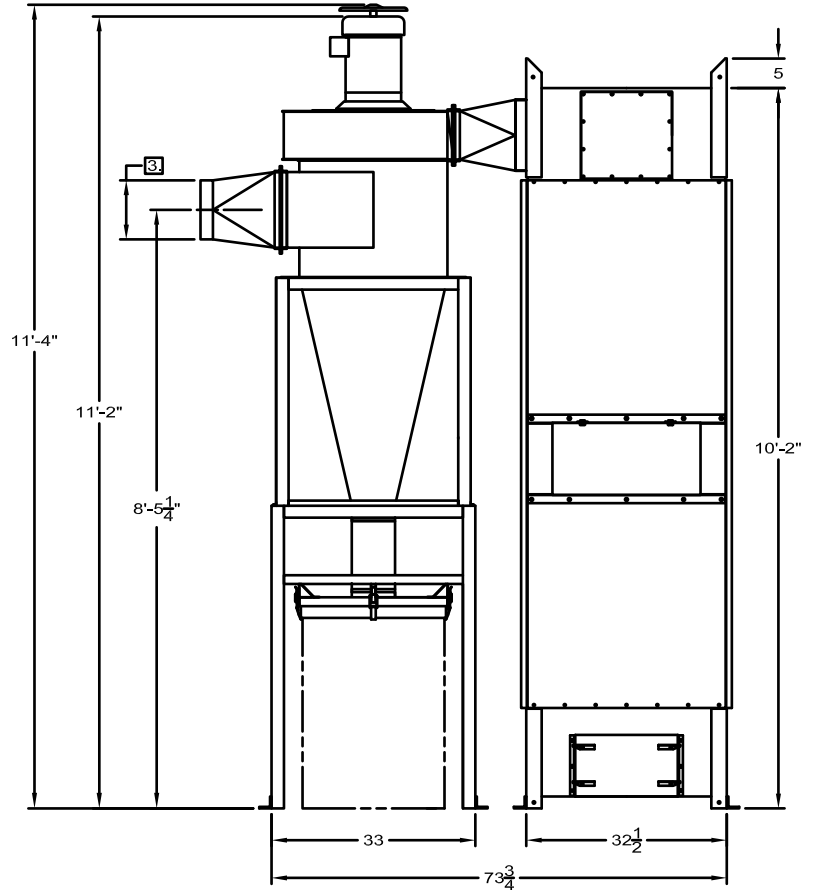
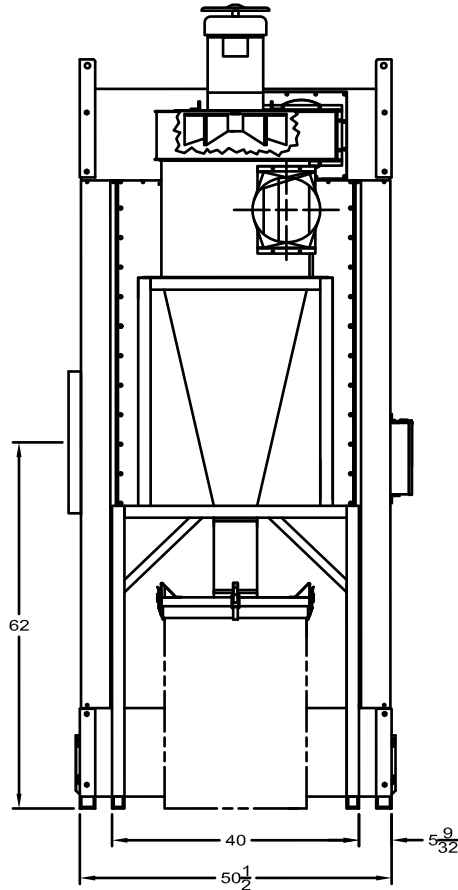

Model	Weights
MNX-30SN90	880 lbs
FT40E	710 lbs

- 5. REFER TO INDIVIDUAL UNIT PRINTS FOR PARTS AND DETAILS
- 4. FILTER AREA - 375 SQ. FT.
- 3. OPTIONAL INLET SIZES - 10", 11", OR 12" I.D.
- 2. TOTAL DUST STORAGE CAPACITY - 7.3 CU. FT. CYCLONE, 14.8 CU. FT. FILTER
- 1. CUSTOMER TO SUPPLY ONE (1) 55 GALLON DRUMS FOR DUST STORAGE

■ NOTE ■