

**TECHNICAL  
INFORMATION**

In the interest of continuing product improvement,  
we reserve the right to change models,  
specifications, and/or features without prejudice.

PROJECT: \_\_\_\_\_  
 LOCATION: \_\_\_\_\_  
 ARCHITECT: \_\_\_\_\_  
 ENGINEER: \_\_\_\_\_  
 CONTRACTOR: \_\_\_\_\_  
 DATE: \_\_\_\_\_ SALES ENGINEER: \_\_\_\_\_

**MNX-30SN90  
with FT400**

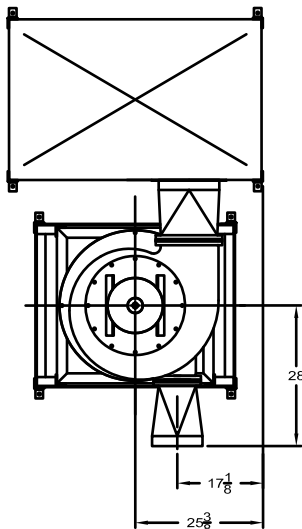
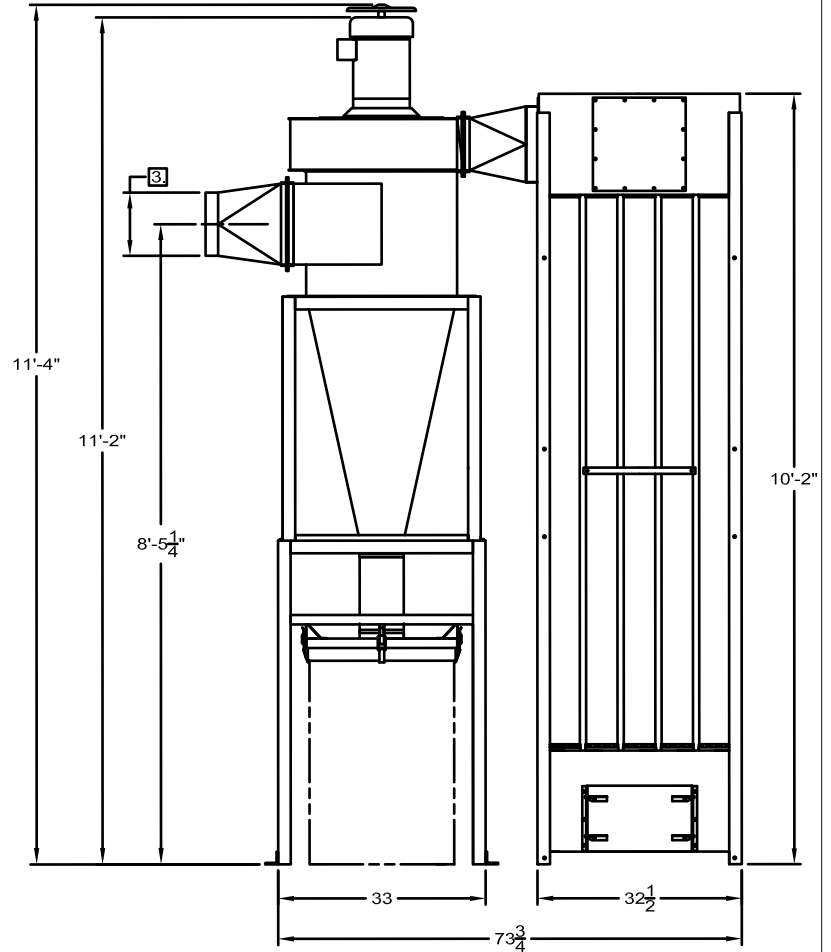
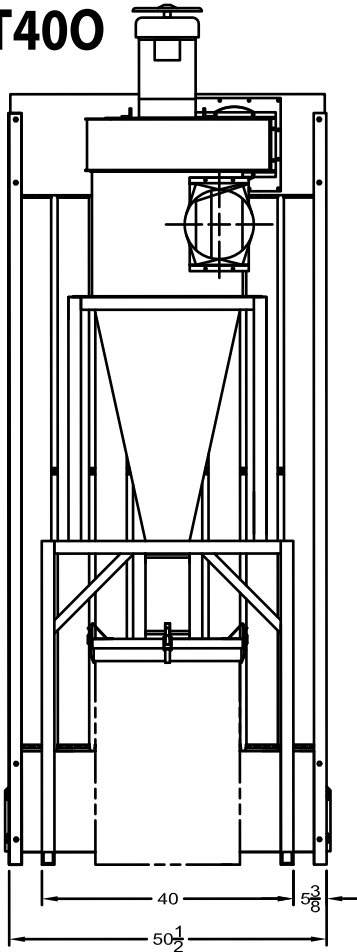

| Model      | Weights |
|------------|---------|
| MNX-30SN90 | 880 lbs |
| FT400      | 550 lbs |

- 5. REFER TO INDIVIDUAL UNIT PRINTS FOR PARTS AND DETAILS
- 4. FILTER AREA - 383 SQ. FT.
- 3. OPTIONAL INLET SIZES - 10", 11", OR 12" I.D.
- 2. TOTAL DUST STORAGE CAPACITY - 7.3 CU. FT. CYCLONE, 14.8 CU. FT. FLITER
- 1. CUSTOMER TO SUPPLY ONE (1) 55 GALLON DRUMS FOR DUST STORAGE

■ **NOTE** ■