

**TECHNICAL
INFORMATION**

In the interest of continuing product improvement,
we reserve the right to change models,
specifications, and/or features without prejudice.

PROJECT: _____
LOCATION: _____
ARCHITECT: _____
ENGINEER: _____
CONTRACTOR: _____
DATE: _____ SALES ENGINEER: _____

SWIVEL BOOM

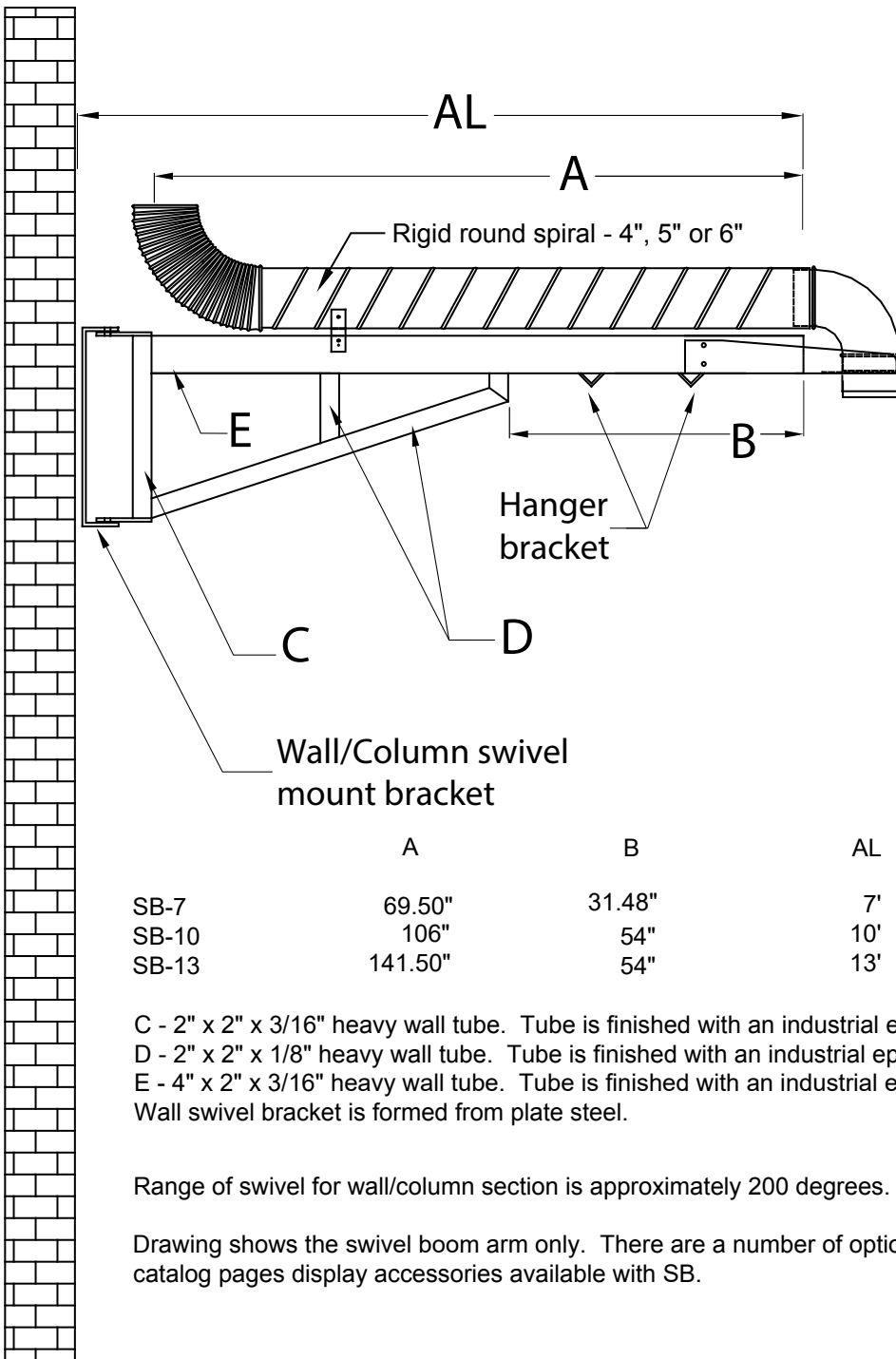

	A	B	AL
SB-7	69.50"	31.48"	7'
SB-10	106"	54"	10'
SB-13	141.50"	54"	13'

C - 2" x 2" x 3/16" heavy wall tube. Tube is finished with an industrial epoxy powder coat finish.
D - 2" x 2" x 1/8" heavy wall tube. Tube is finished with an industrial epoxy powder coat finish.
E - 4" x 2" x 3/16" heavy wall tube. Tube is finished with an industrial epoxy powder coat finish.
Wall swivel bracket is formed from plate steel.

Range of swivel for wall/column section is approximately 200 degrees.

Drawing shows the swivel boom arm only. There are a number of options for attachment. Other catalog pages display accessories available with SB.