

**TECHNICAL INFORMATION**

In the interest of continuing product improvement, we reserve the right to change models, specifications, and/or features without prejudice.

PROJECT: \_\_\_\_\_  
 LOCATION: \_\_\_\_\_  
 ARCHITECT: \_\_\_\_\_  
 ENGINEER: \_\_\_\_\_  
 CONTRACTOR: \_\_\_\_\_  
 DATE: \_\_\_\_\_ SALES ENGINEER: \_\_\_\_\_

**Custom Slotted Fume Hoods**

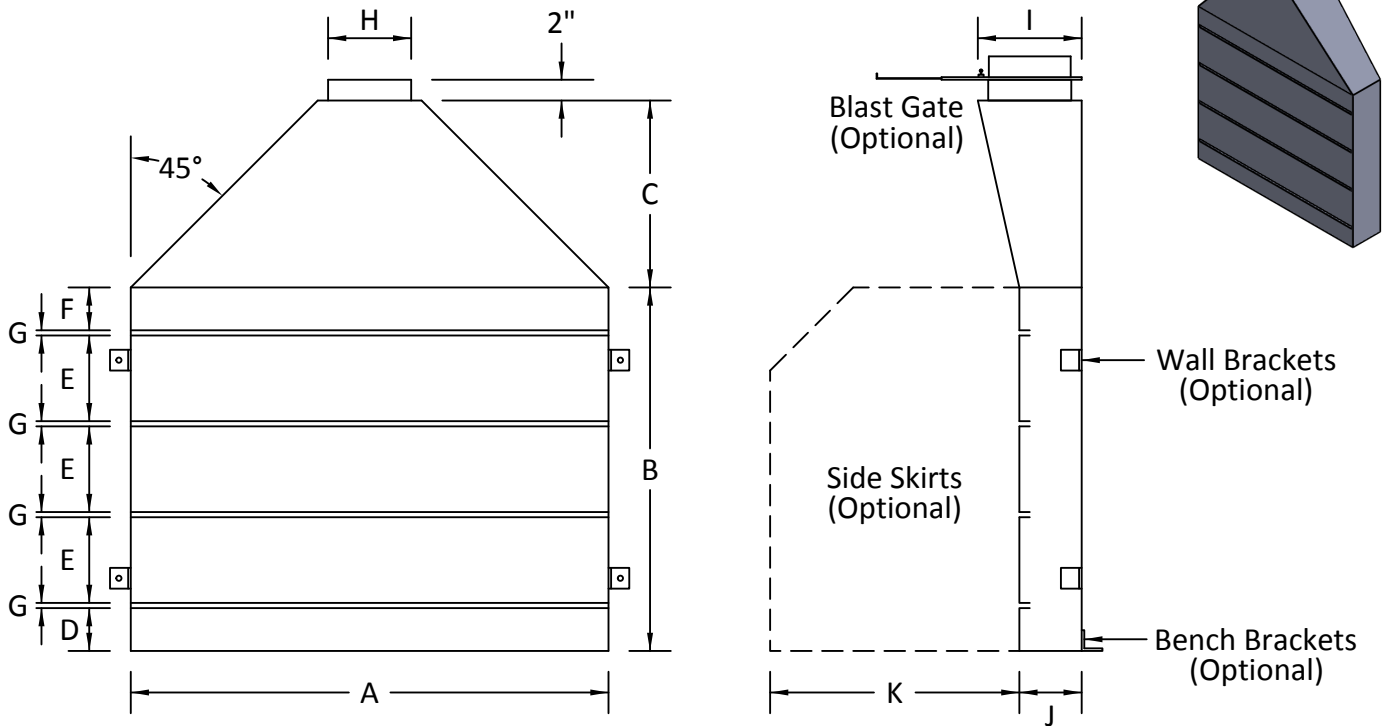

Qty.	Material	Gauge	No. of Slots	No. of Sections	A	B	C	D	E	F

G	H	I	J	K	No. of Side Skirts	Finish	Options	Tag

**Finishes:**

- Mill Finish
- Painted
- Powder Coated
- Primer Only
- Custom Colors

**Standard Construction:**

- 18-gauge Welded Galvannealed

**Available Materials:**

- Steel
- Stainless Steel
- Aluminum
- Galvanized
- Corrosion Resistant FRP
- \* Thickness 26 ga. to 10 ga.

**Options:**

- Side Skirts
- Blast Gate
- Wall Bracket
- Bench Bracket
- Adjustable Slots

**Notes:**

- Standard are four equally spaced 1/2 inch spaces. Alternate slot configurations available
- Reference 28th Edition - Industrial Ventilation Guidelines for design assistance.