

**TECHNICAL
INFORMATION**

In the interest of continuing product improvement,
we reserve the right to change models,
specifications, and/or features without prejudice.

PROJECT: _____
LOCATION: _____
ARCHITECT: _____
ENGINEER: _____
CONTRACTOR: _____
DATE: _____ SALES ENGINEER: _____

Standard Double Hopper Downdraft Table

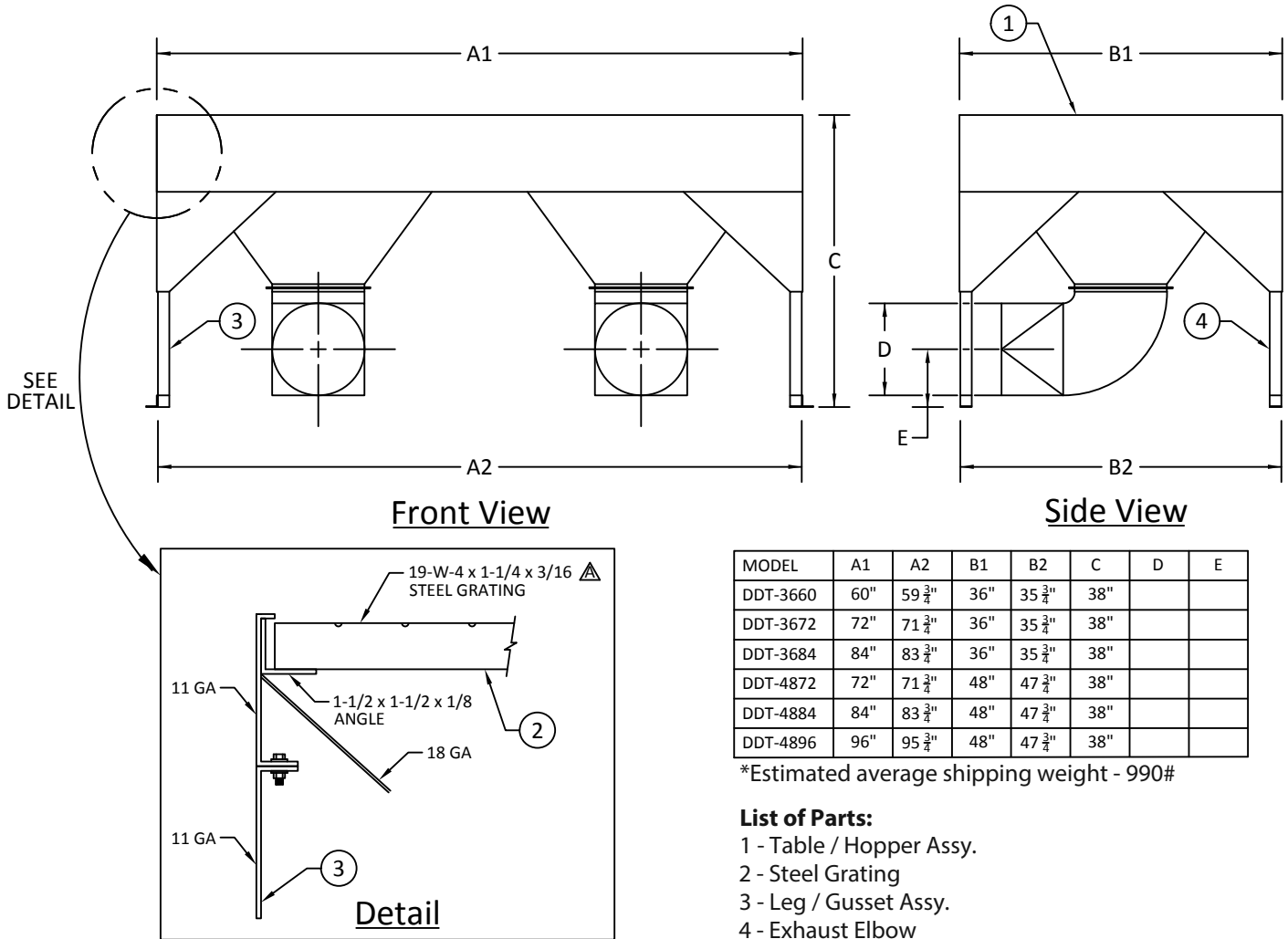

MODEL	A1	A2	B1	B2	C	D	E
DDT-3660	60"	59 3/4"	36"	35 3/4"	38"		
DDT-3672	72"	71 3/4"	36"	35 3/4"	38"		
DDT-3684	84"	83 3/4"	36"	35 3/4"	38"		
DDT-4872	72"	71 3/4"	48"	47 3/4"	38"		
DDT-4884	84"	83 3/4"	48"	47 3/4"	38"		
DDT-4896	96"	95 3/4"	48"	47 3/4"	38"		

*Estimated average shipping weight - 990#

List of Parts:

- 1 - Table / Hopper Assy.
- 2 - Steel Grating
- 3 - Leg / Gusset Assy.
- 4 - Exhaust Elbow

Notes:

- "D" Sizing based on exhaust rate
- Exhaust design: 150 - 250 CFM / Sq. Ft. table surface area
- Special side shields available at extra cost
- Special grating materials available at extra cost
- Overall height can be altered to meet job requirements; consult factory; standard height "C" noted
- Reference 28th Edition - Industrial Ventilation Guidelines for design assistance.