

**TECHNICAL  
INFORMATION**

In the interest of continuing product improvement,  
we reserve the right to change models,  
specifications, and/or features without prejudice.

PROJECT: \_\_\_\_\_  
LOCATION: \_\_\_\_\_  
ARCHITECT: \_\_\_\_\_  
ENGINEER: \_\_\_\_\_  
CONTRACTOR: \_\_\_\_\_  
DATE: \_\_\_\_\_ SALES ENGINEER: \_\_\_\_\_

www.monoxivent.com

info@monoxivent.com

309-794-1000

Page: WSC-35

**Custom Double Hopper Downdraft Table**

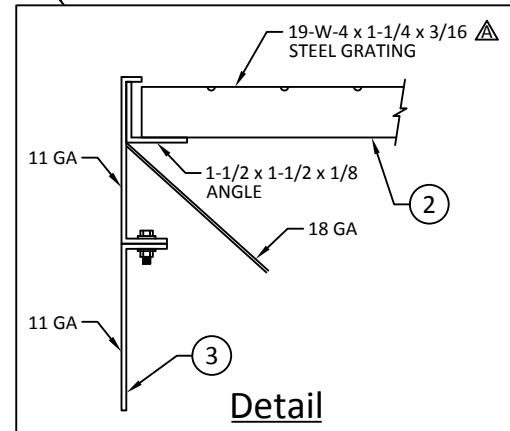
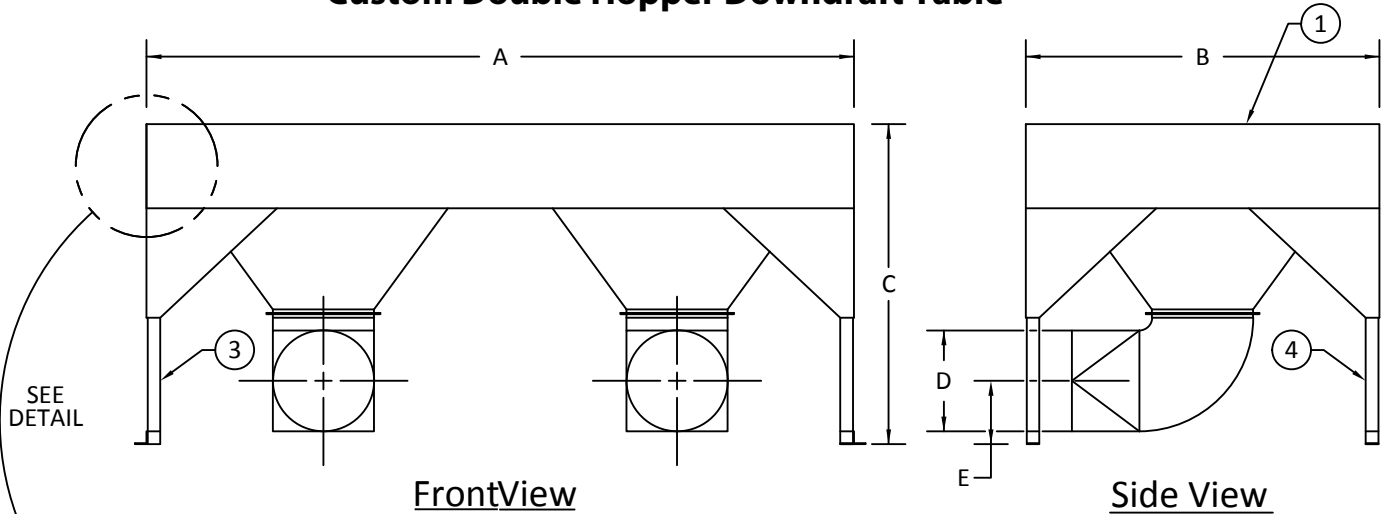

Qty.	Material	Gauge	A	B

C	D	E	Finish	Tag

**Finishes:**

- Mill Finish
- Painted
- Powder Coated
- Primer Only
- Custom Colors

**Standard Construction:**

- 11-gauge Welded Galvannealed

**Available Materials:**

- Steel
- Stainless Steel
- Aluminum
- Galvanized
- Corrosion Resistant FRP

**Options (Check Applicable):**

- 4" Side Skirts
- 6" Side Skirts
- 8" Side Skirts
- Adjustable Legs

**Notes:**

- Reference 28th Edition - Industrial Ventilation Guidelines for design assistance.
- Exhaust design: 150 - 250 CFM / Sq. Ft. table surface area

**List of Parts:**

- 1 - Table / Hopper Assy.
- 2 - Steel Grating
- 3 - Leg / Gusset Assy.
- 4 - Exhaust Elbow